

MATLAB EXPO

2021

Motor HIL for Powertrains: From Spatial Harmonics to System Level Simulation

Joel Van Sickel

Abhi Shankar Abhinav

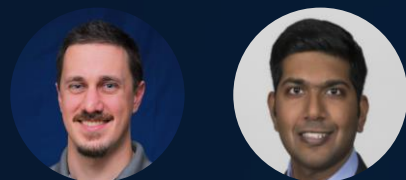

Torque Vectoring Application

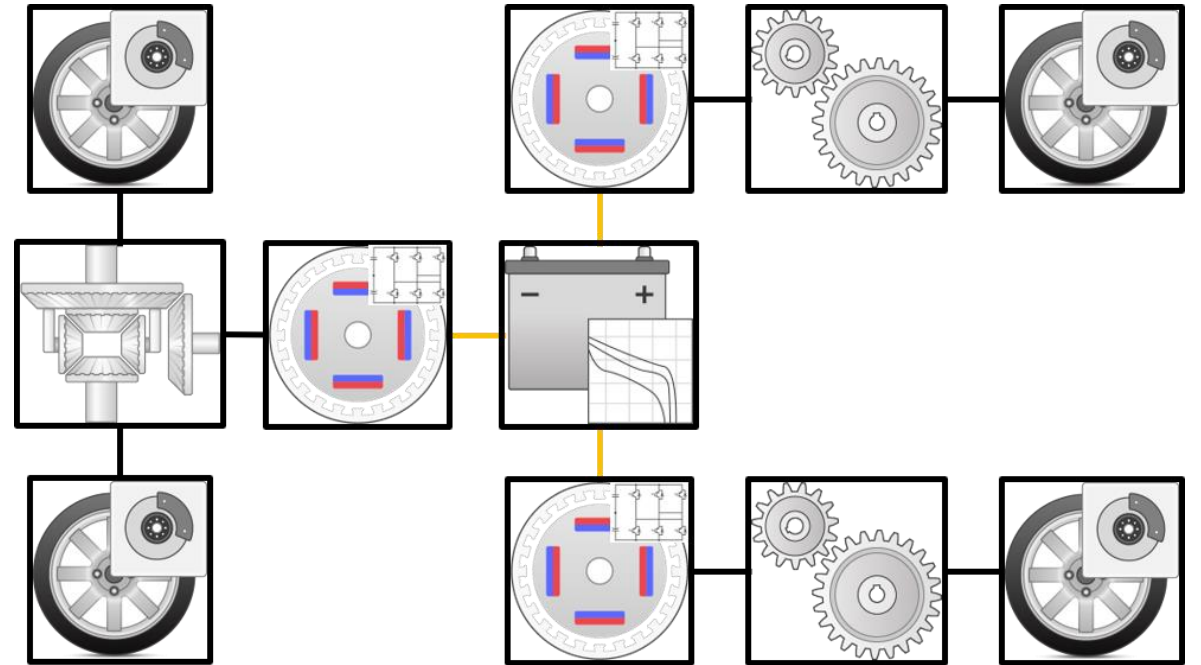
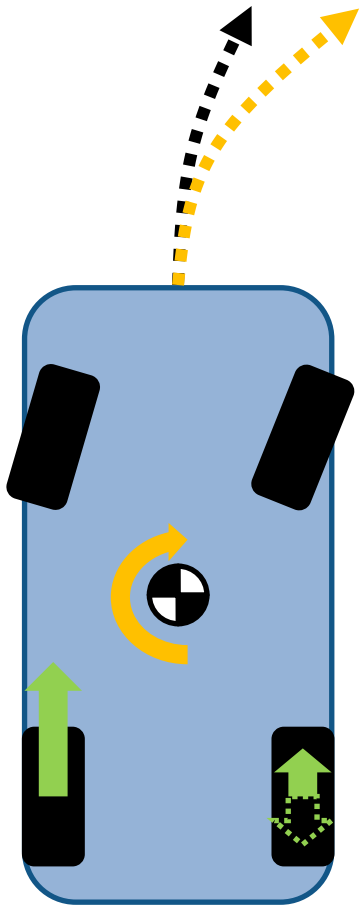

Motor Control

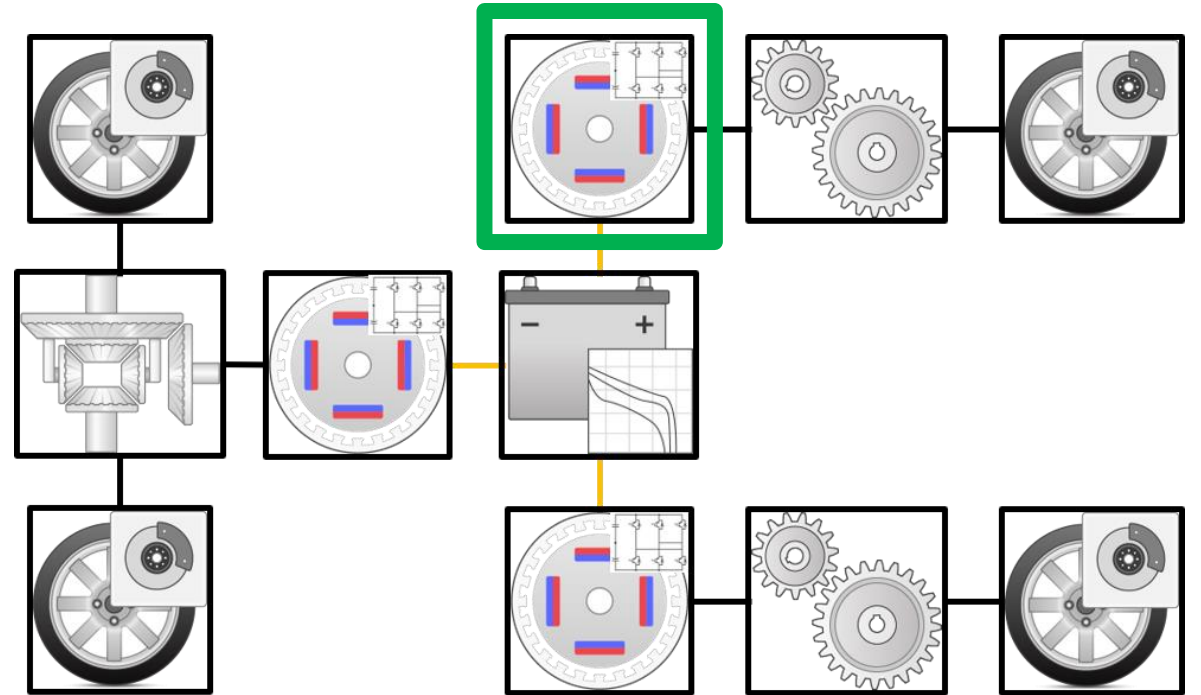
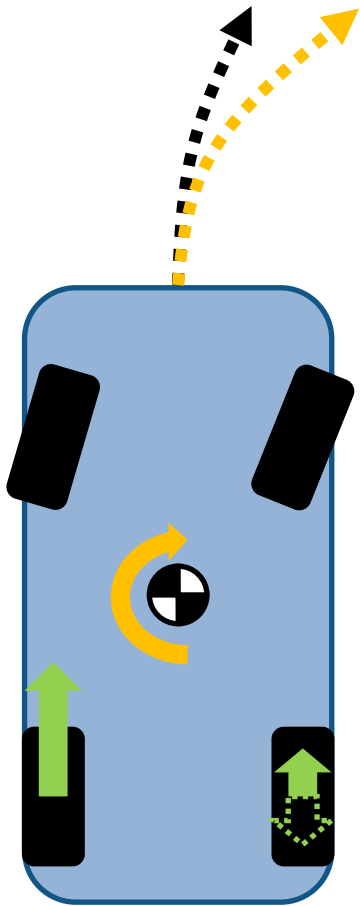

- Motor Control
 - Focus on single motor controller

Torque Vectoring Application

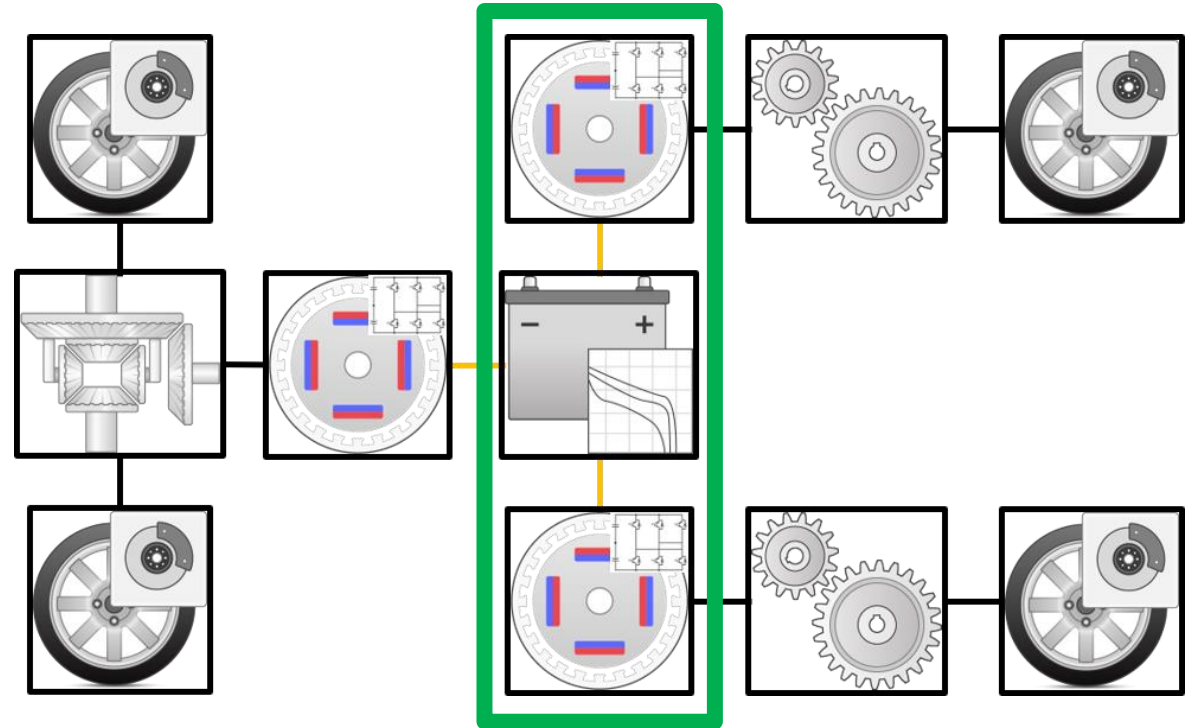
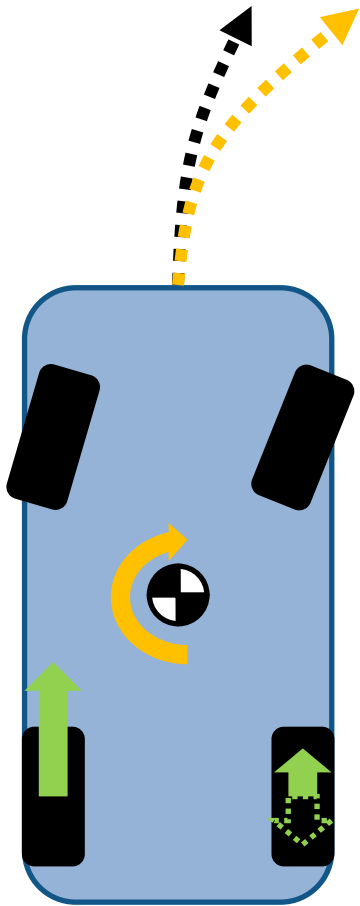

- Torque vectoring
 - Concerned about vehicle dynamics
 - Needs system information in addition to motor dynamics

Motor HIL

Algorithm Model

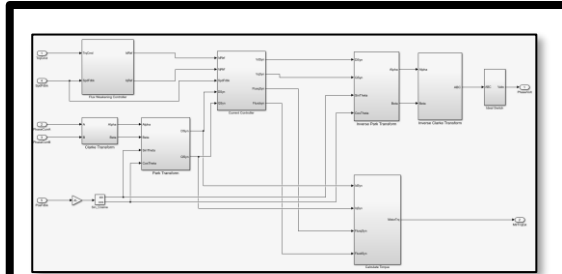

Controller

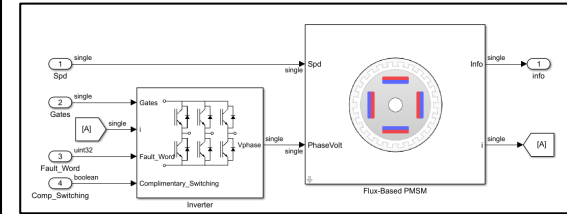

Motor and Inverter Models

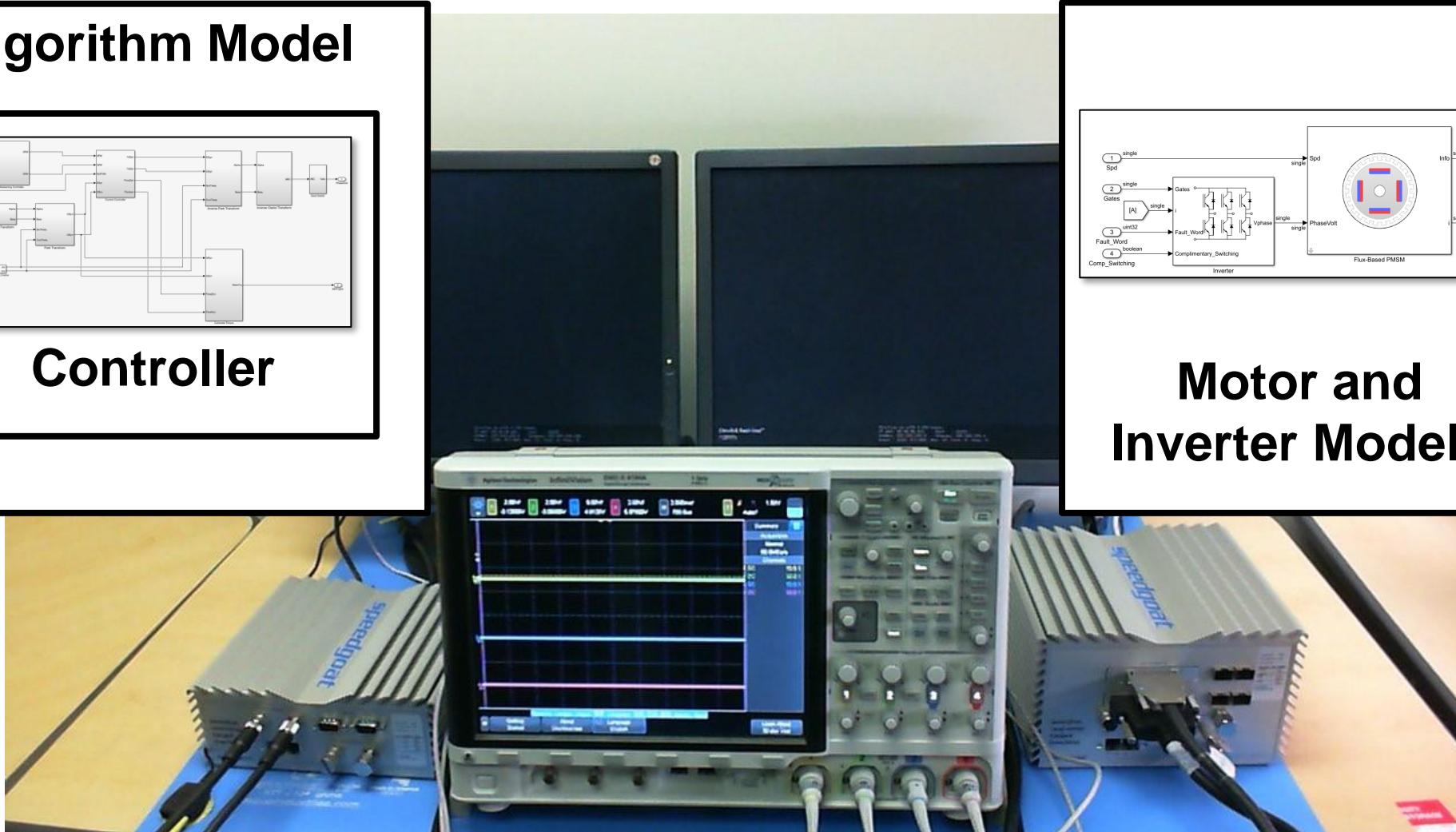

Motor HIL

Algorithm Model

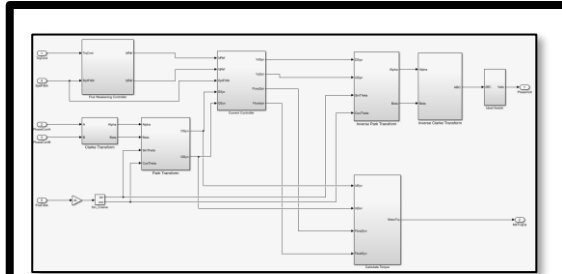

Controller

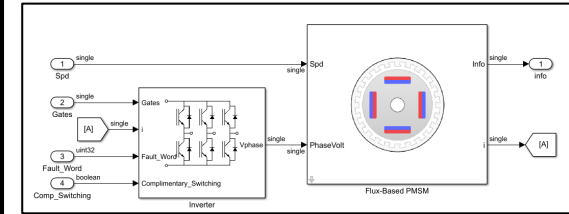

Motor and Inverter Models

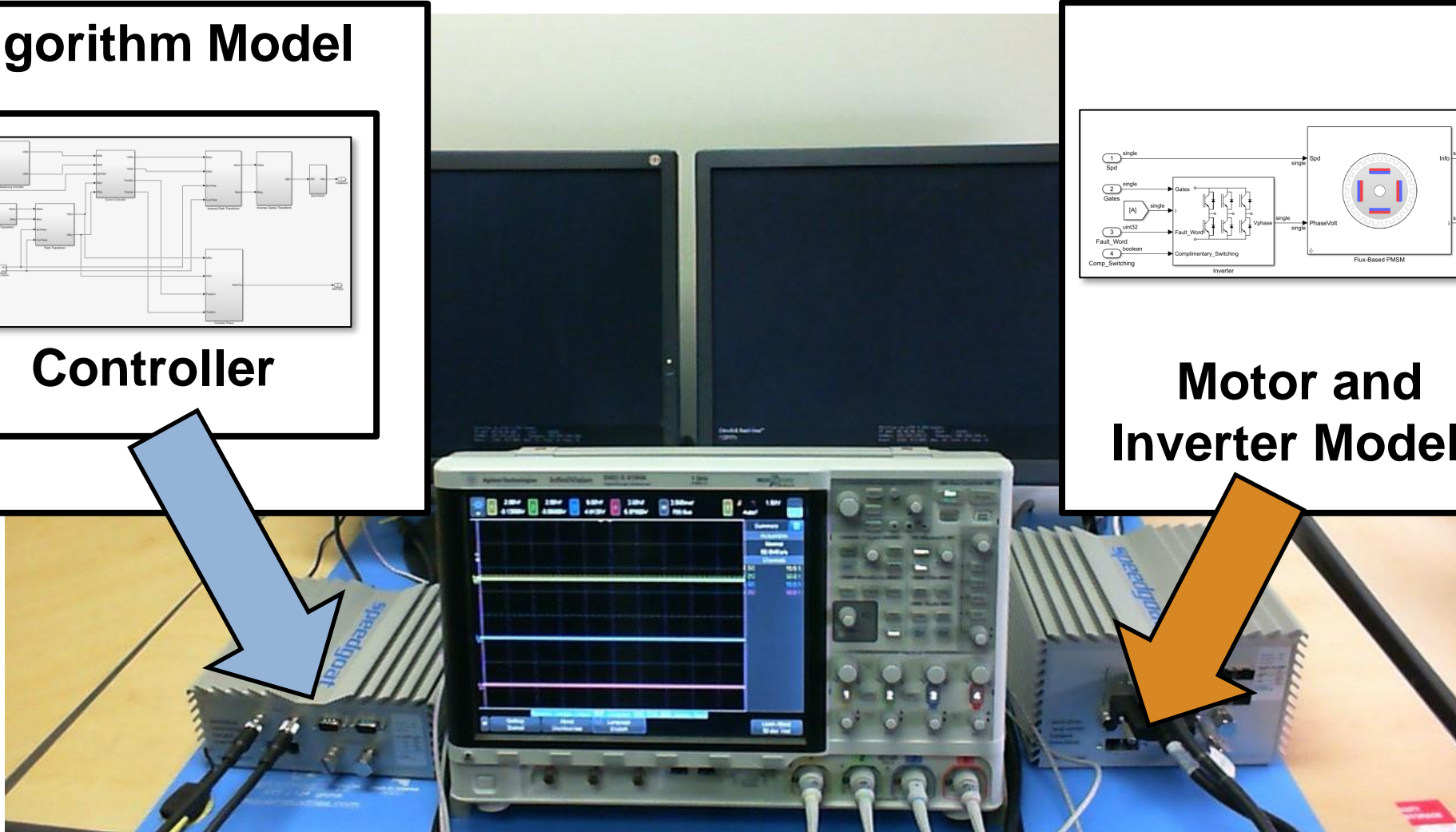

Motor HIL

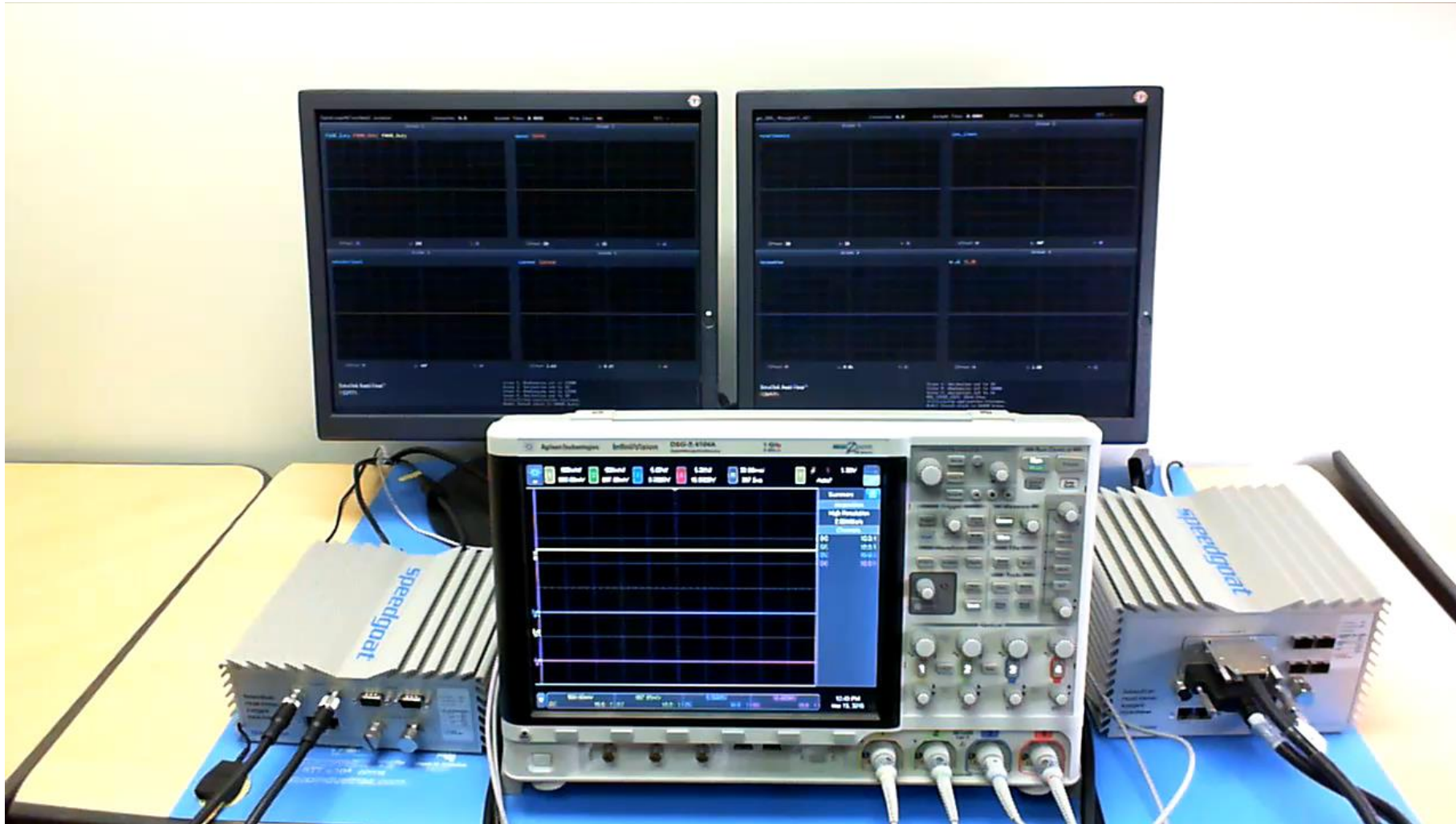

Torque Vectoring Prototype tested against Virtual Vehicle Real-Time Simulation

Controller



Powertrain & Vehicle Dynamics Model

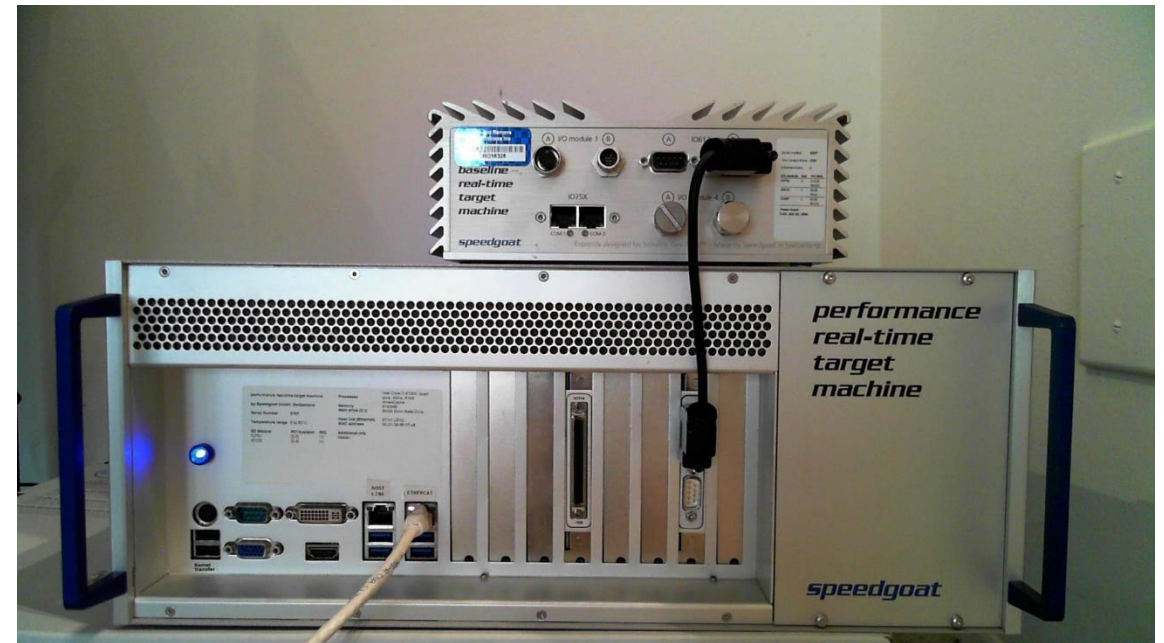

Torque Vectoring Prototype tested against Virtual Vehicle Real-Time Simulation

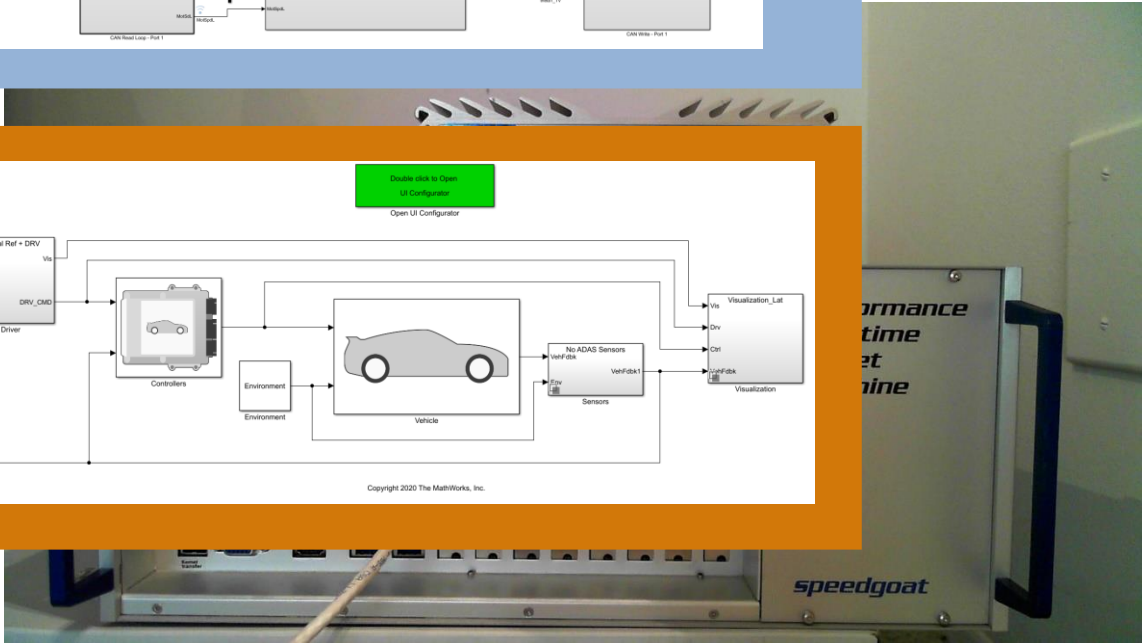
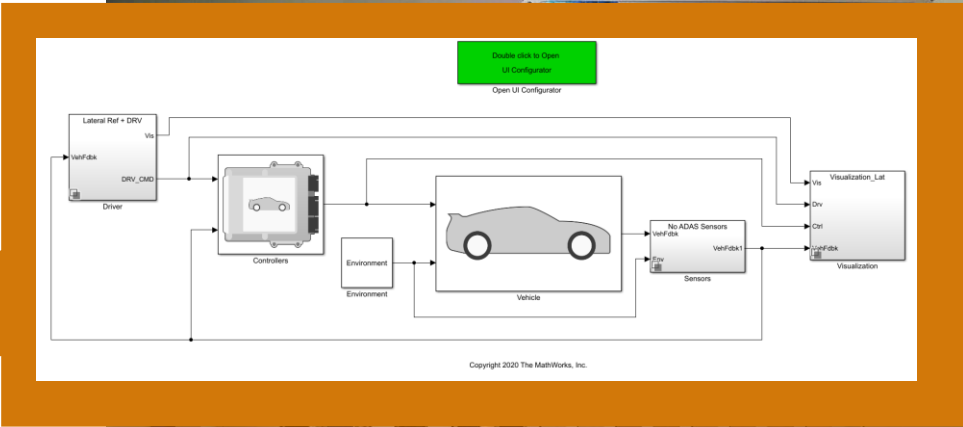
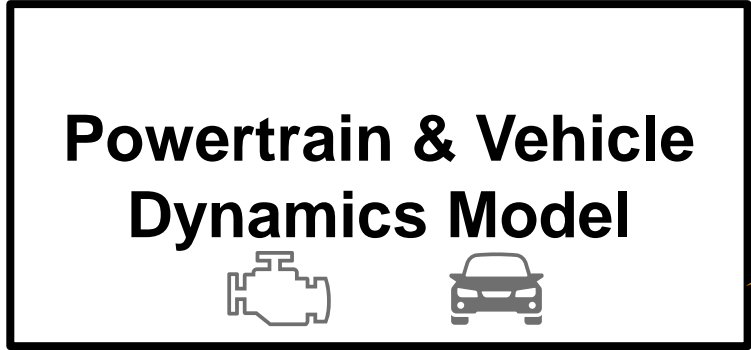
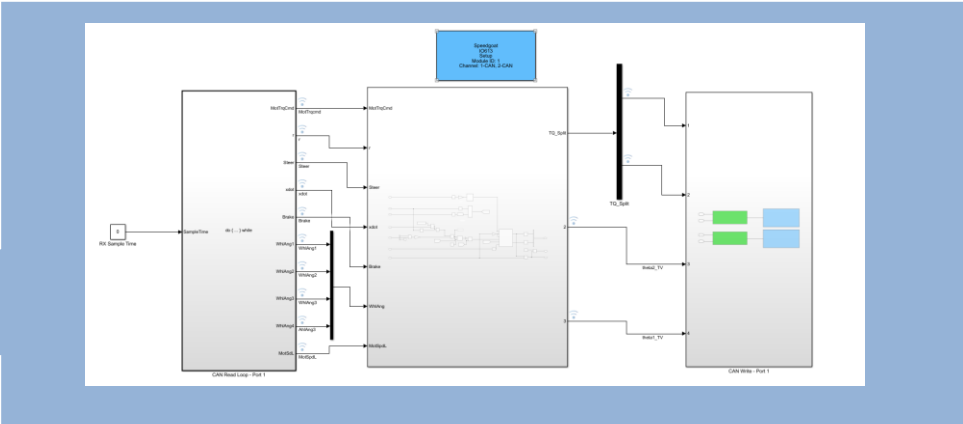
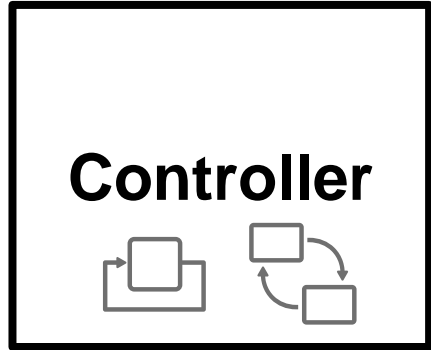

Torque Vectoring Prototype tested against Virtual Vehicle Real-Time Simulation

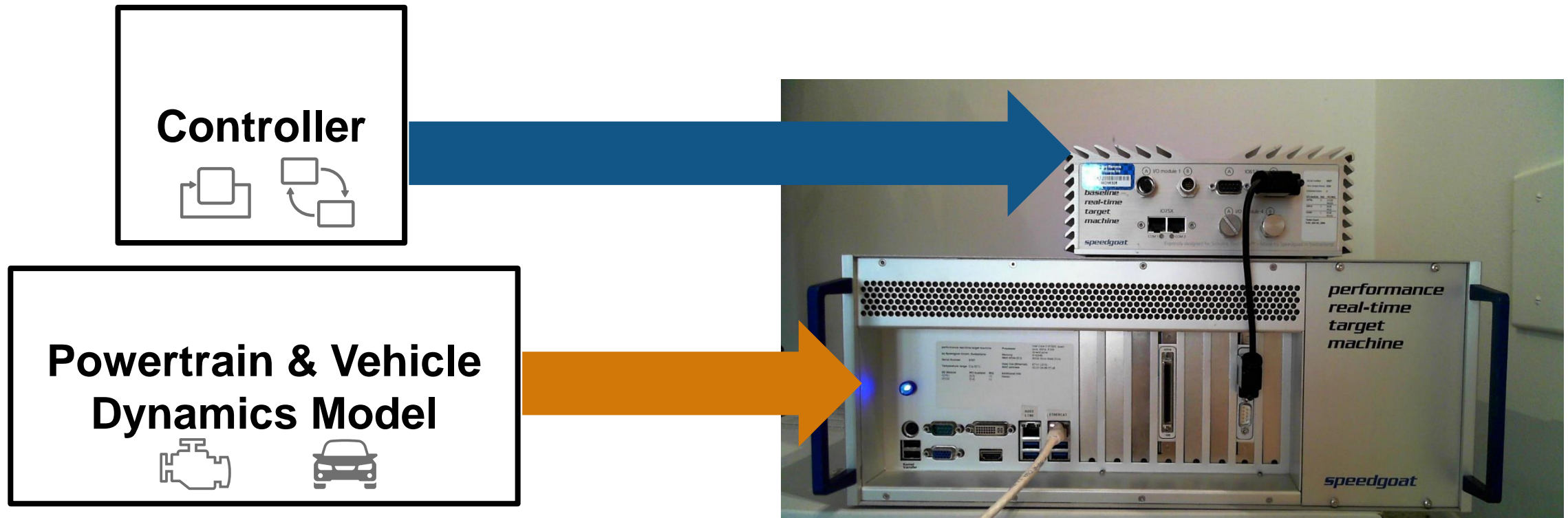

Torque Vectoring Prototype tested against Virtual Vehicle Real-Time Simulation



Why HIL?

Why HIL?

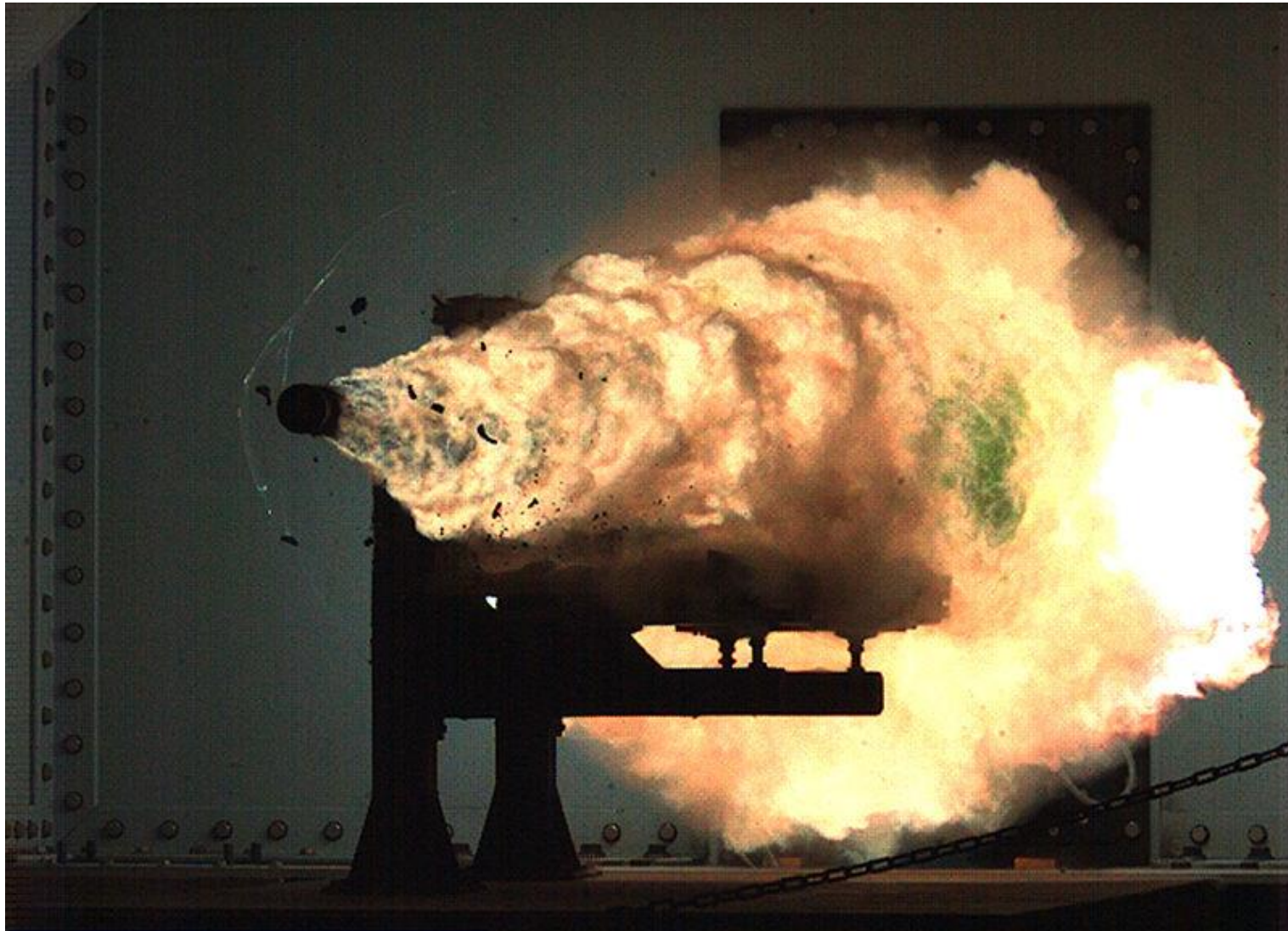

Why HIL?

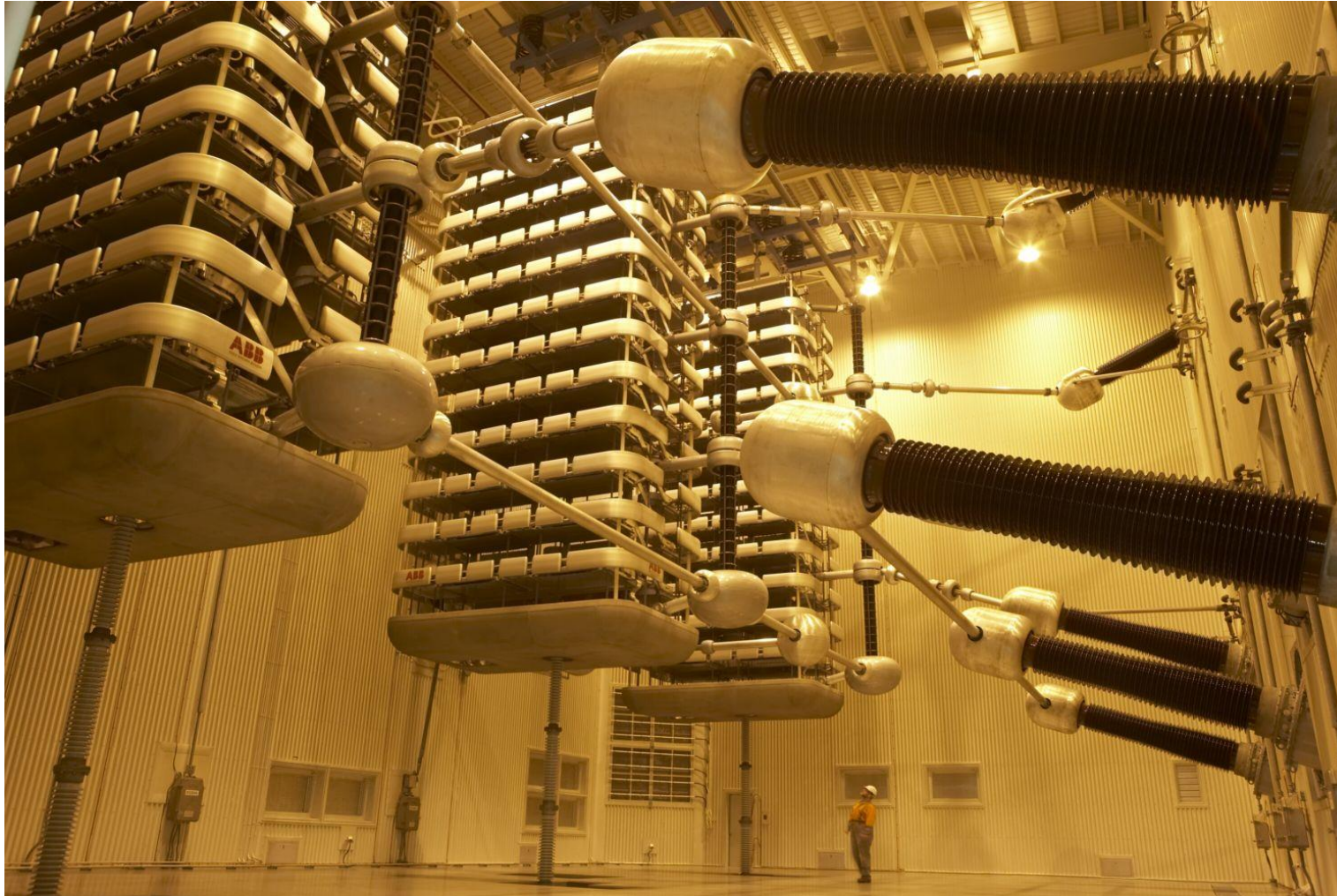

By Marshelec - Own work, CC BY-SA 3.0, <https://commons.wikimedia.org/w/index.php?curid=16585159>

Why HIL?

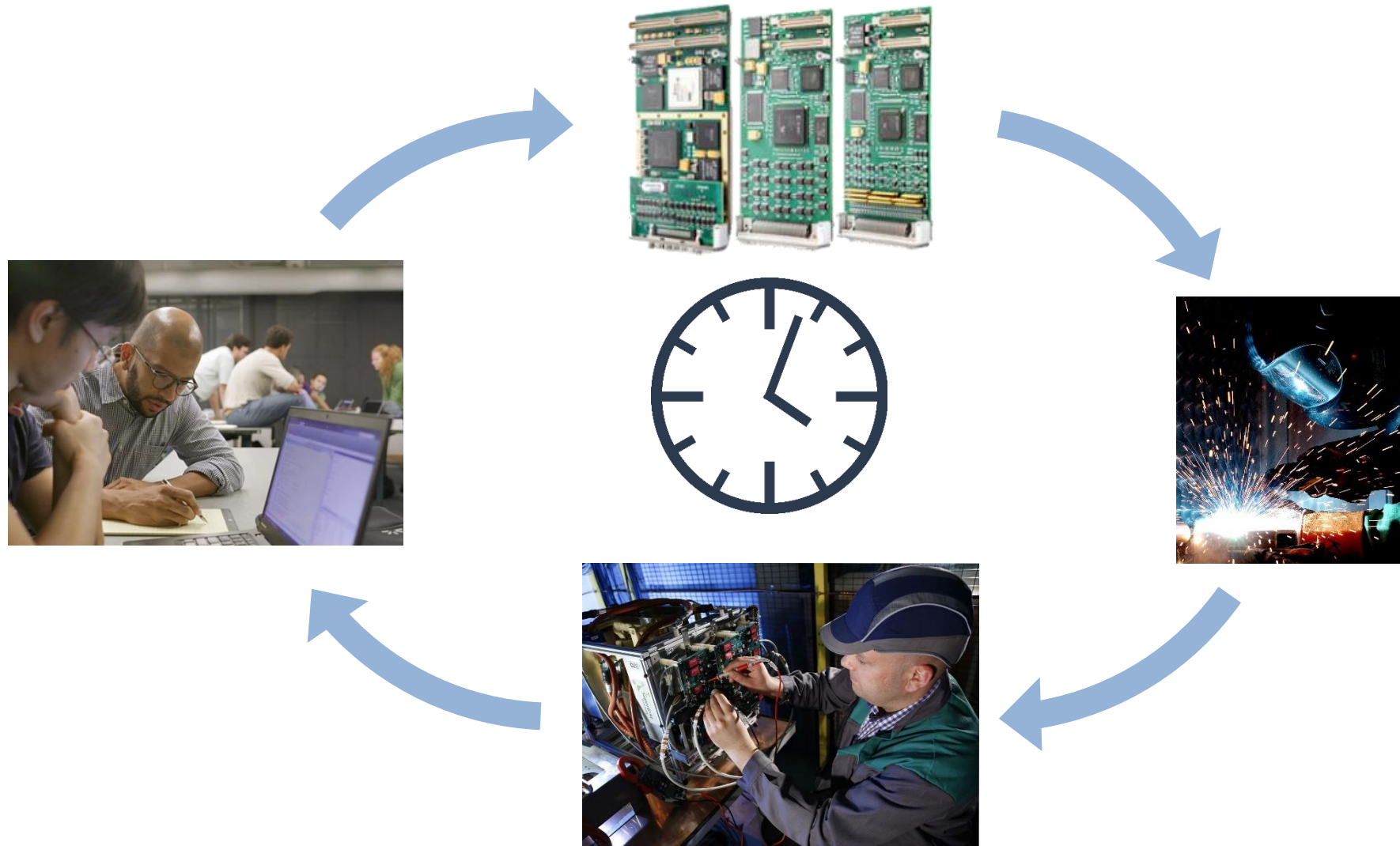

Motor Control

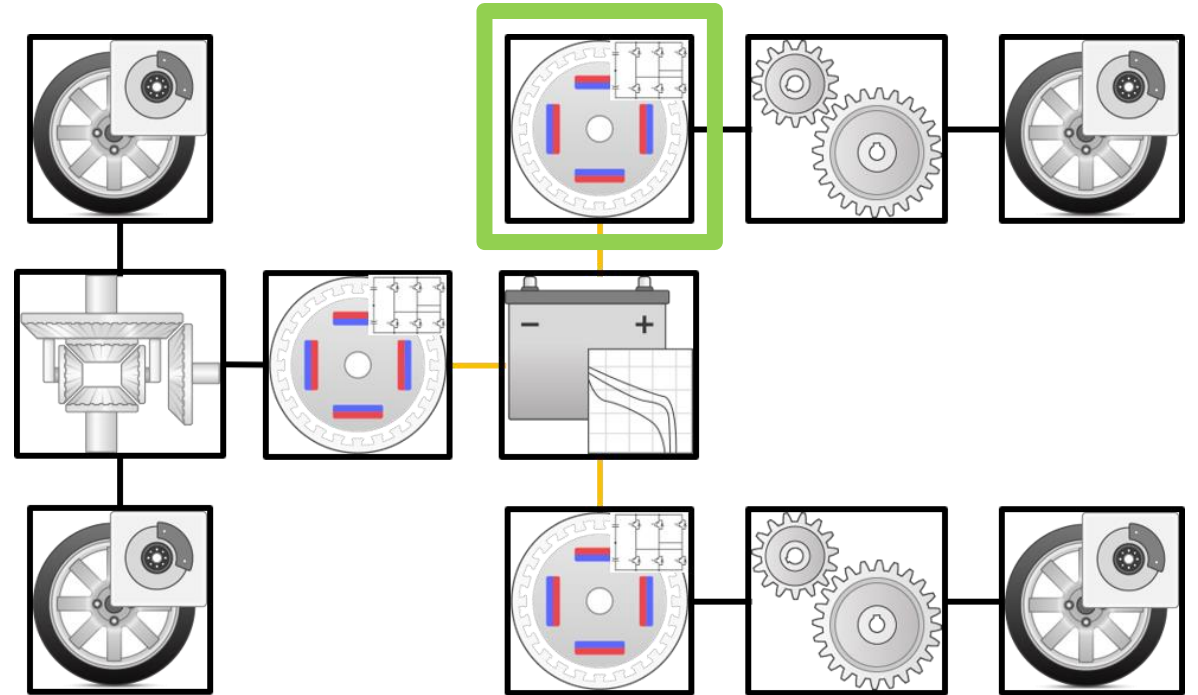
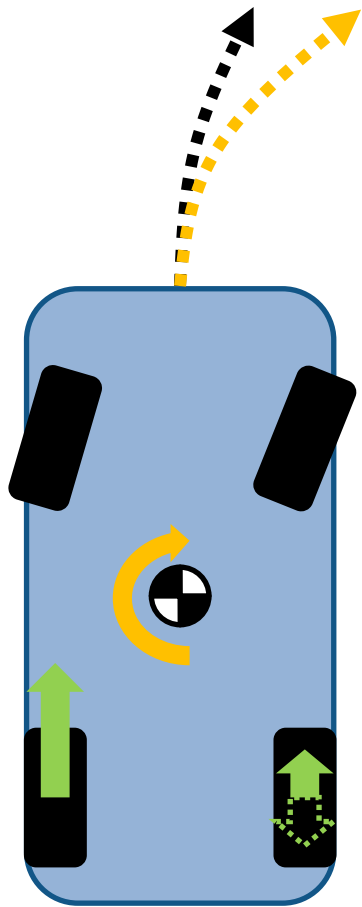

Three Levels of PMSM Model Fidelity

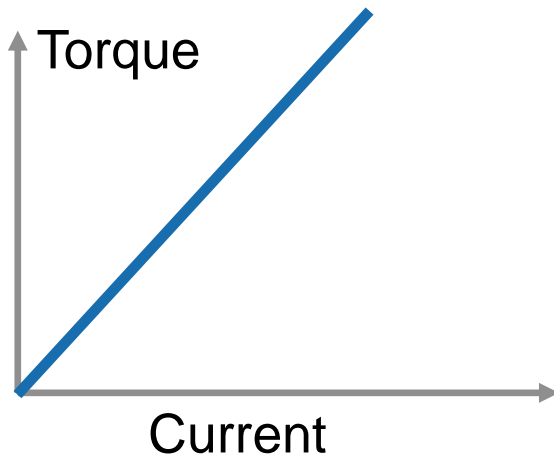

Lumped Parameter

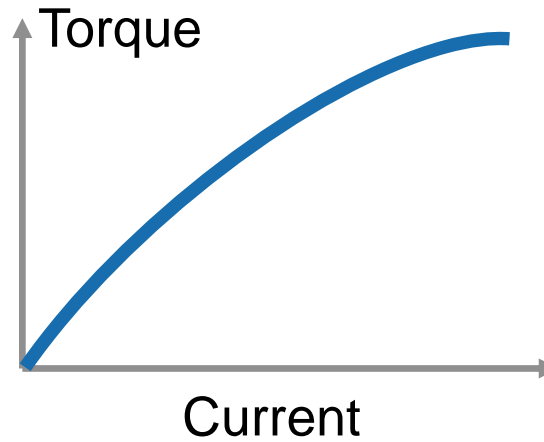

Saturation

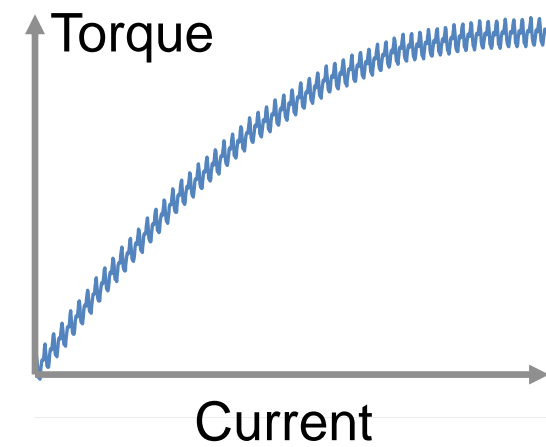

Saturation +
Spatial Harmonics

Nonlinear Flux and Current Tables

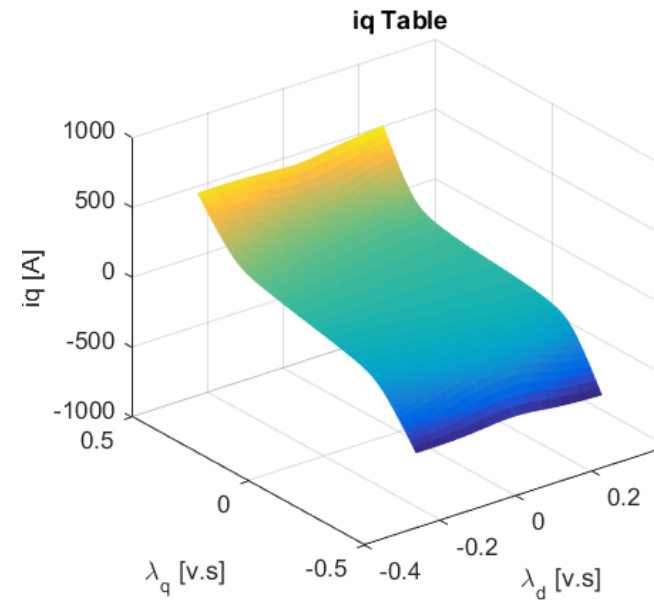
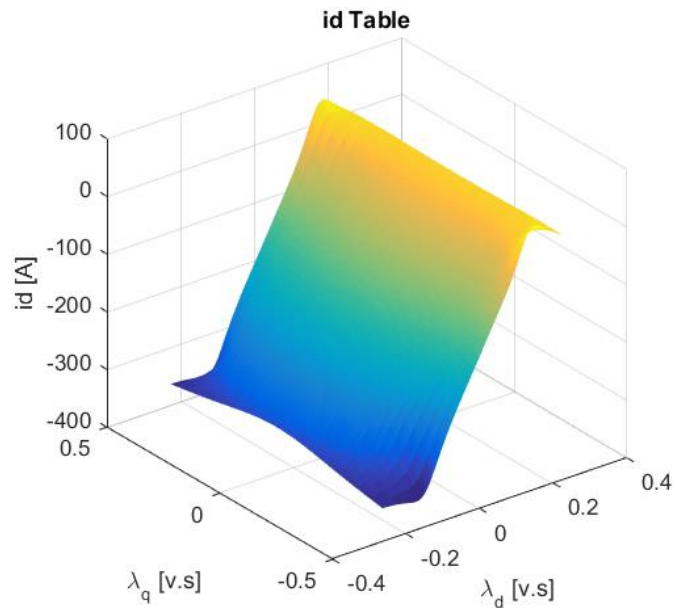
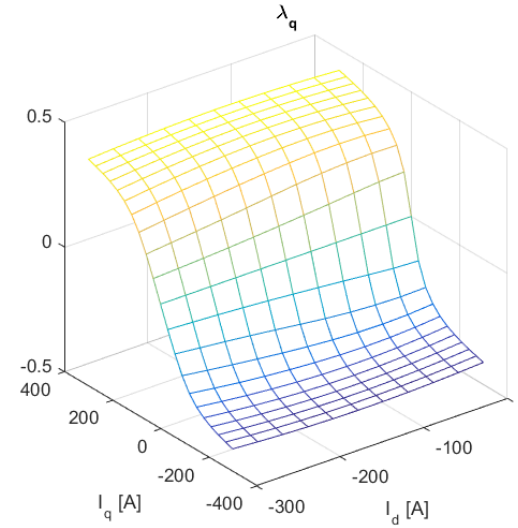
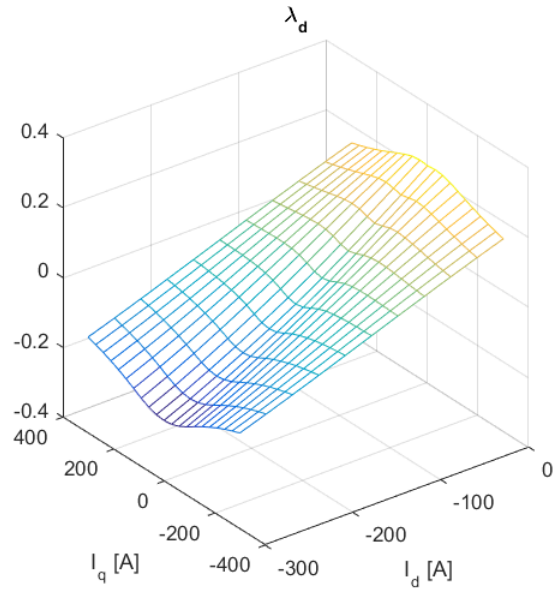

Rotor Position Dependency

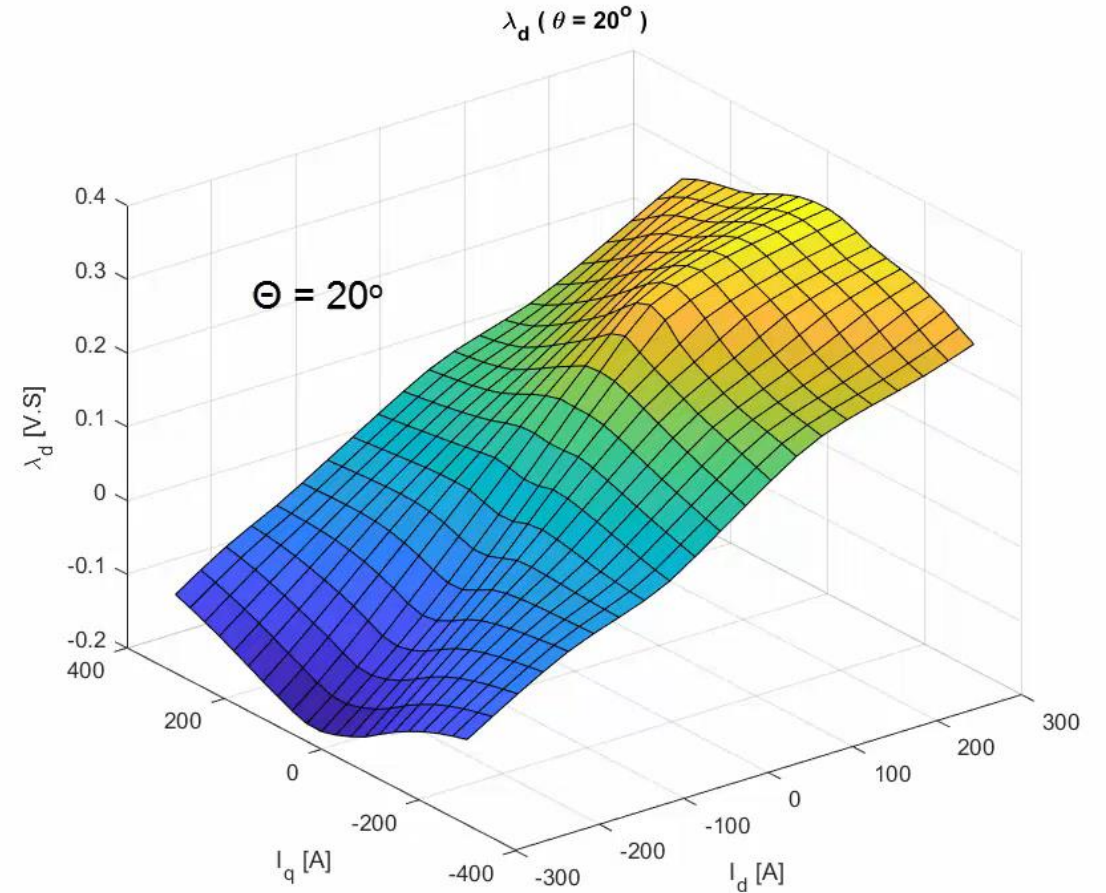
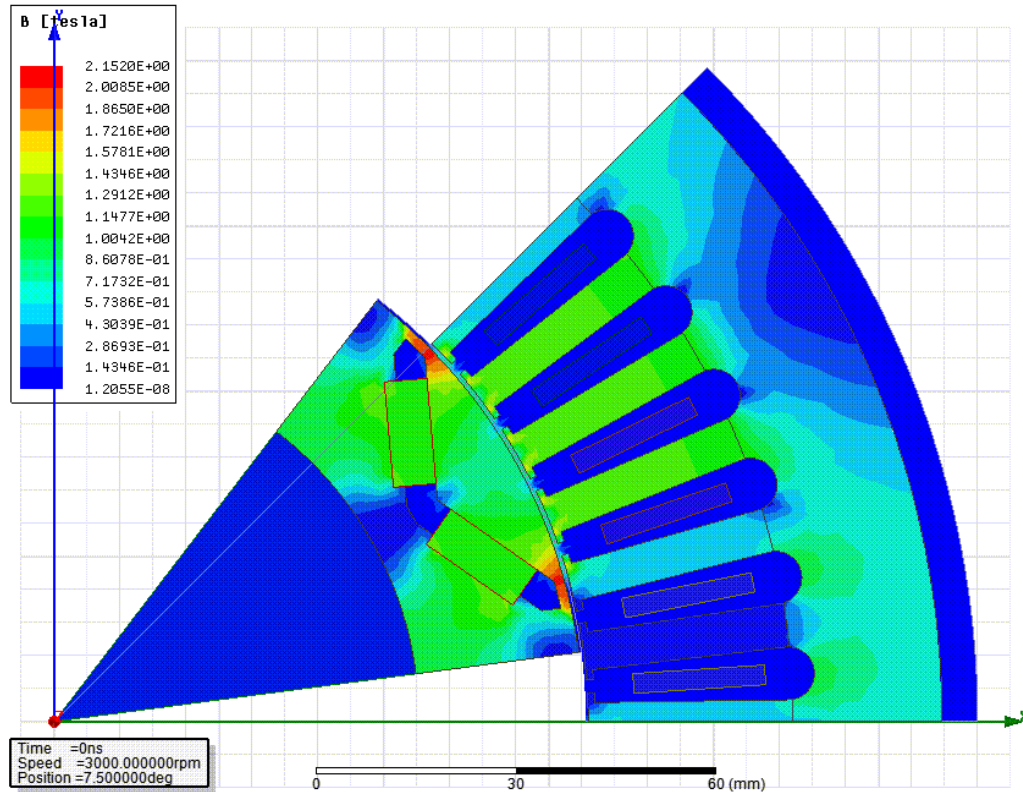

Animation: flux variation at different rotor position

Two Levels of Inverter Model Fidelity

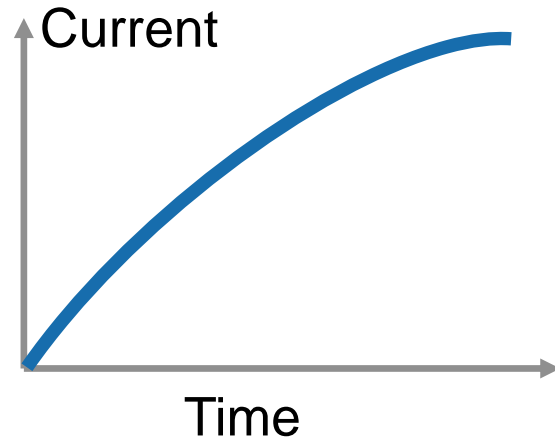

Averaged

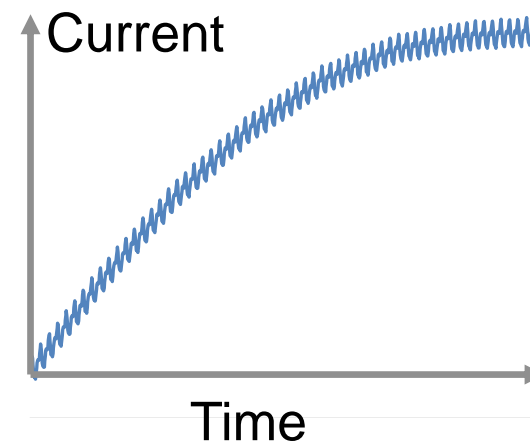

Switched

What Motor and Inverter Model to Use

- Potential Applications
 - Basic E-drive Proof of Concept
 - Average Inverter
 - Lumped Parameter Motor
 - Field Weakening Control
 - Average Inverter
 - Flux Based Motor
 - Torque Ripple Compensation
 - Switching Inverter
 - Spatial Harmonics Based Motor

Review of a System Level Model of a Motor and Inverter in Simulink

FEM Based Motor Model

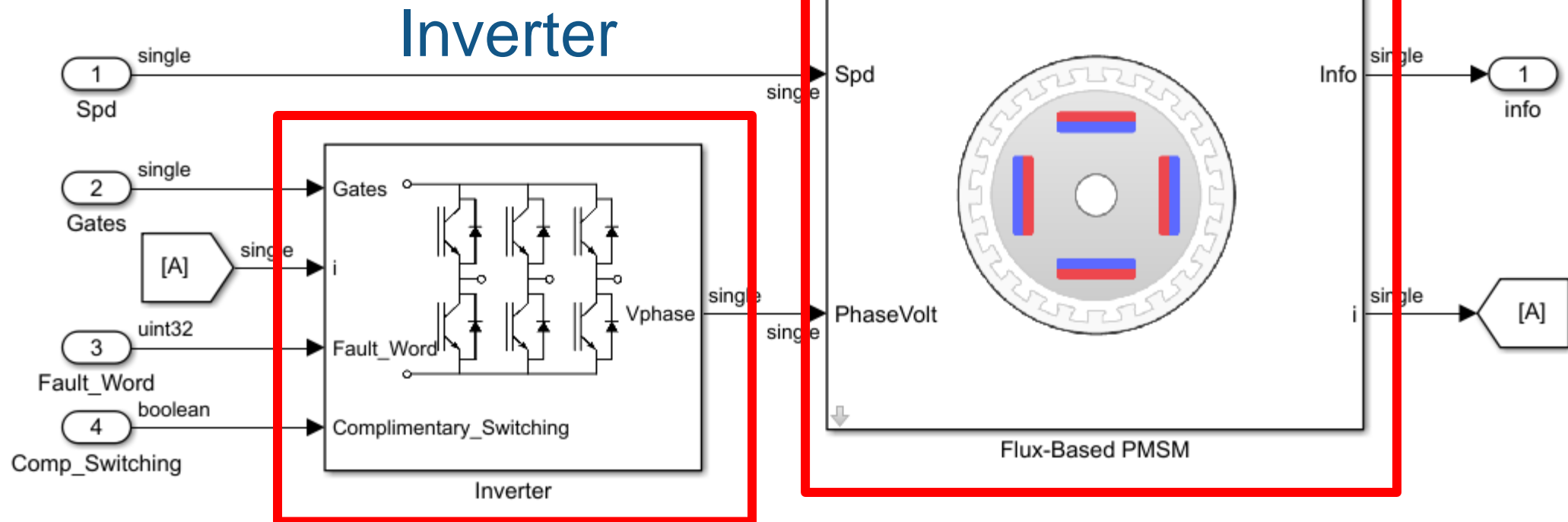

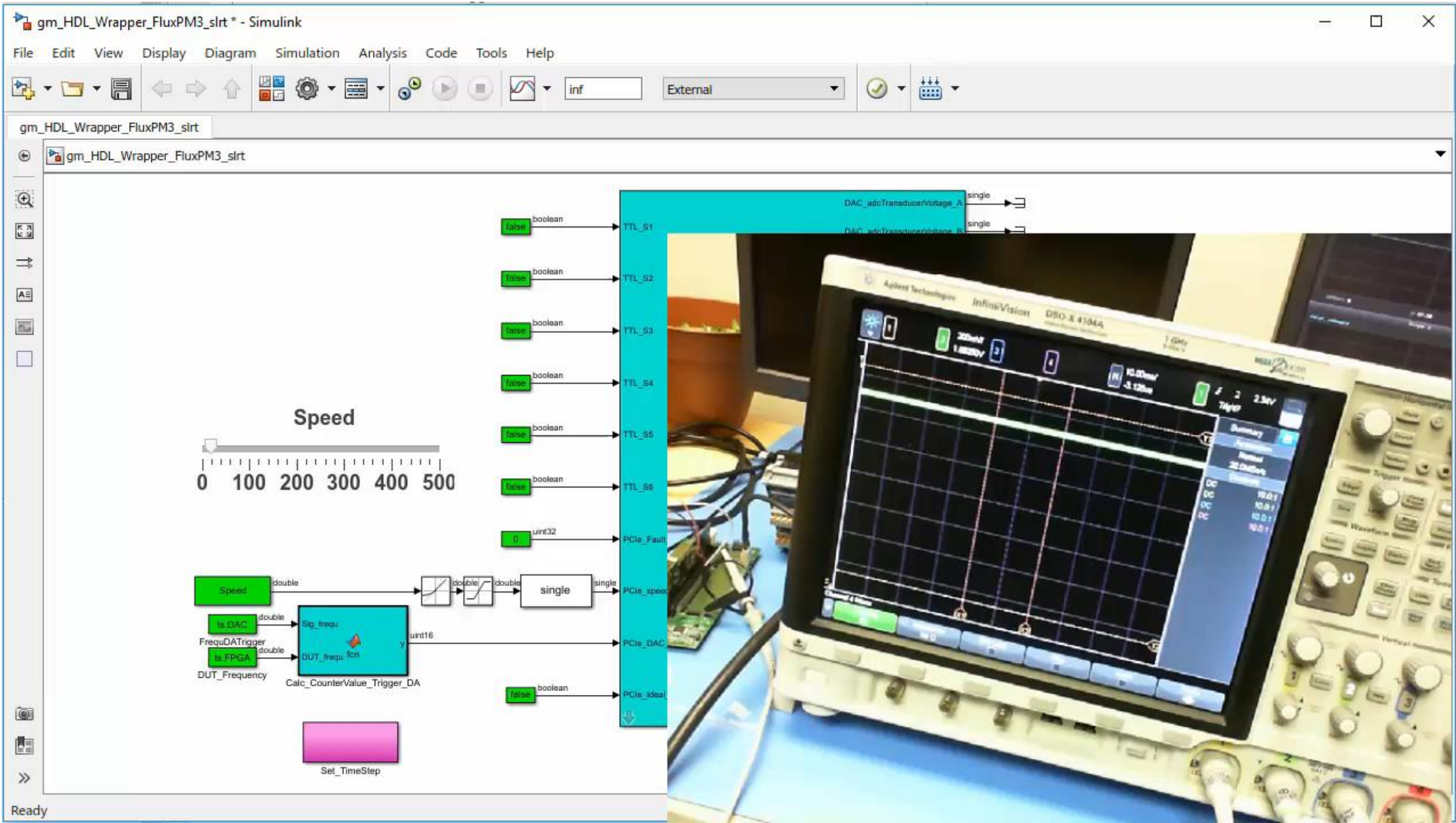

Motor Control HIL

- Works on CPU and FPGA
- Hardware Agnostic
- Supports switching frequency up to 200 kHz

Torque Vectoring Application

- Dual Rear Motors (BEV 3 Motor)

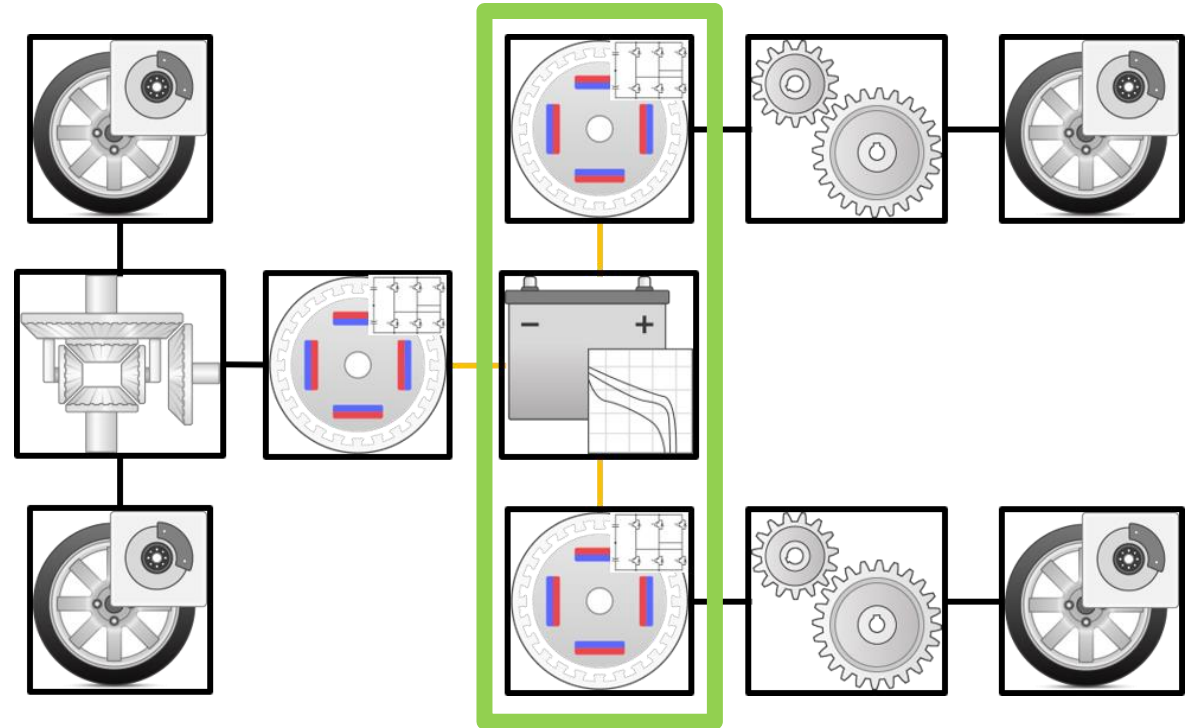
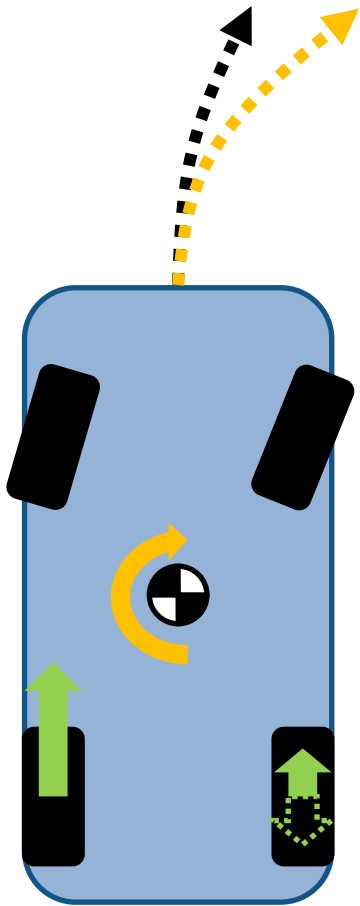

Torque Vectoring Application

- Dual Rear Motors (BEV 3 Motor)

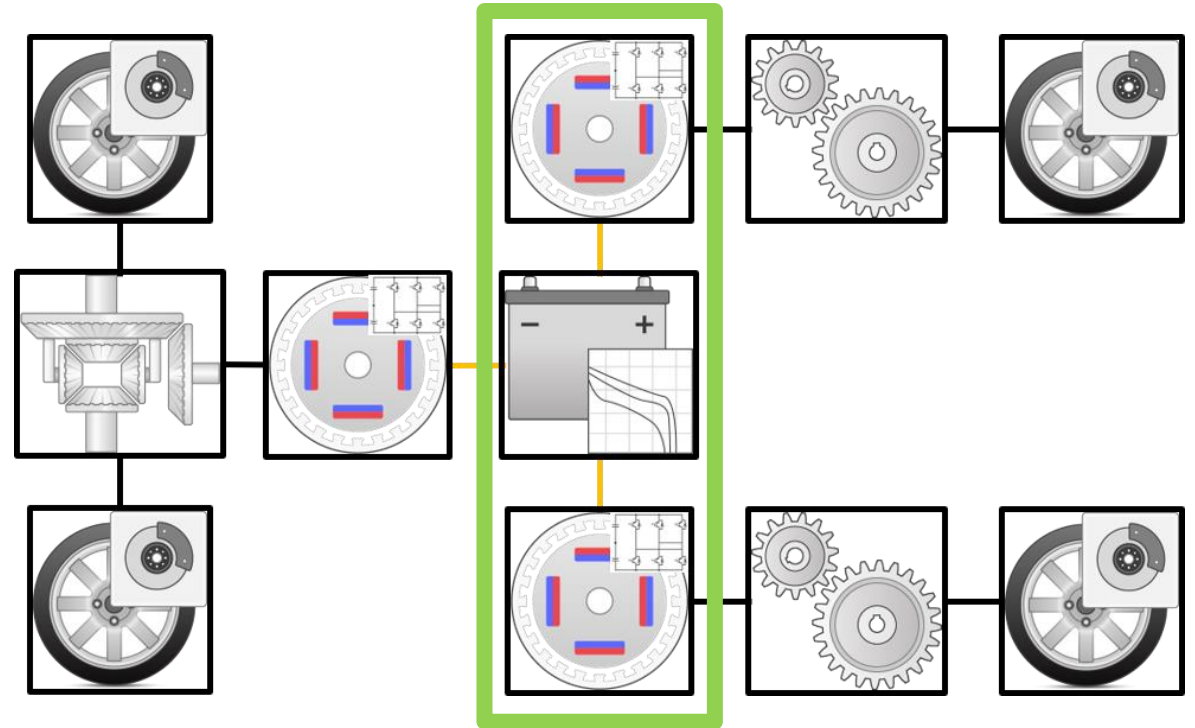
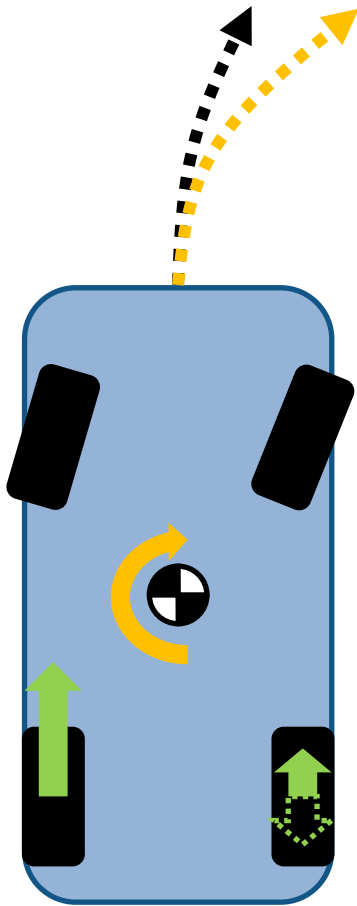

- Torque vectoring
 - Applies different (sometimes opposing) torque to left / right wheels
 - Requires longitudinal and lateral vehicle dynamics models
- Benefit
 - Improved handling
 - Tighter turn radius

Powertrain System Model

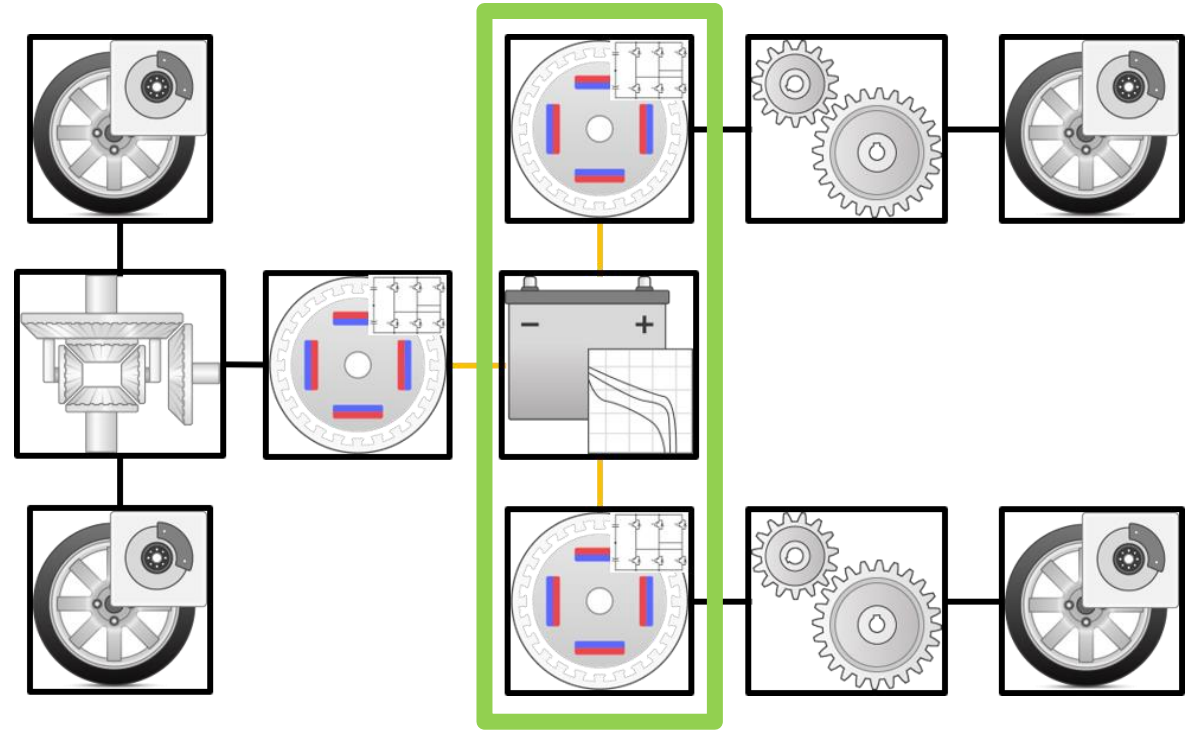

Powertrain System Model

- Mapped Motor

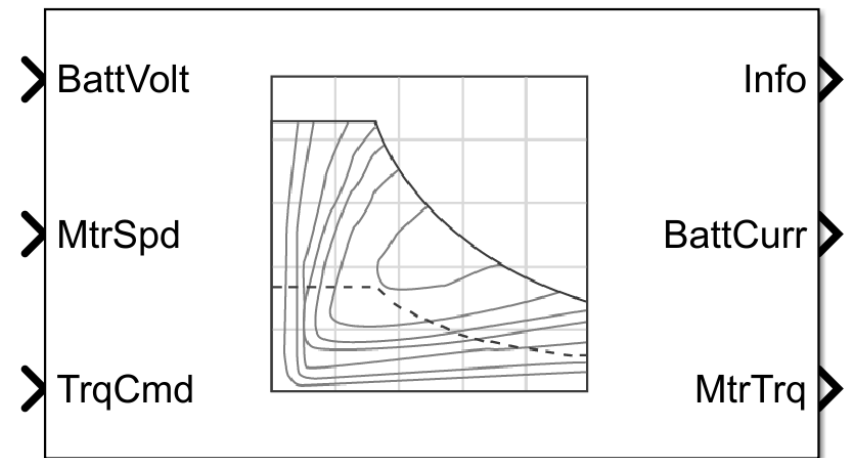
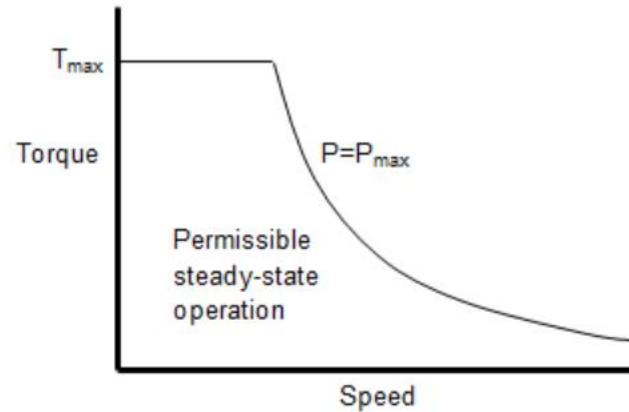
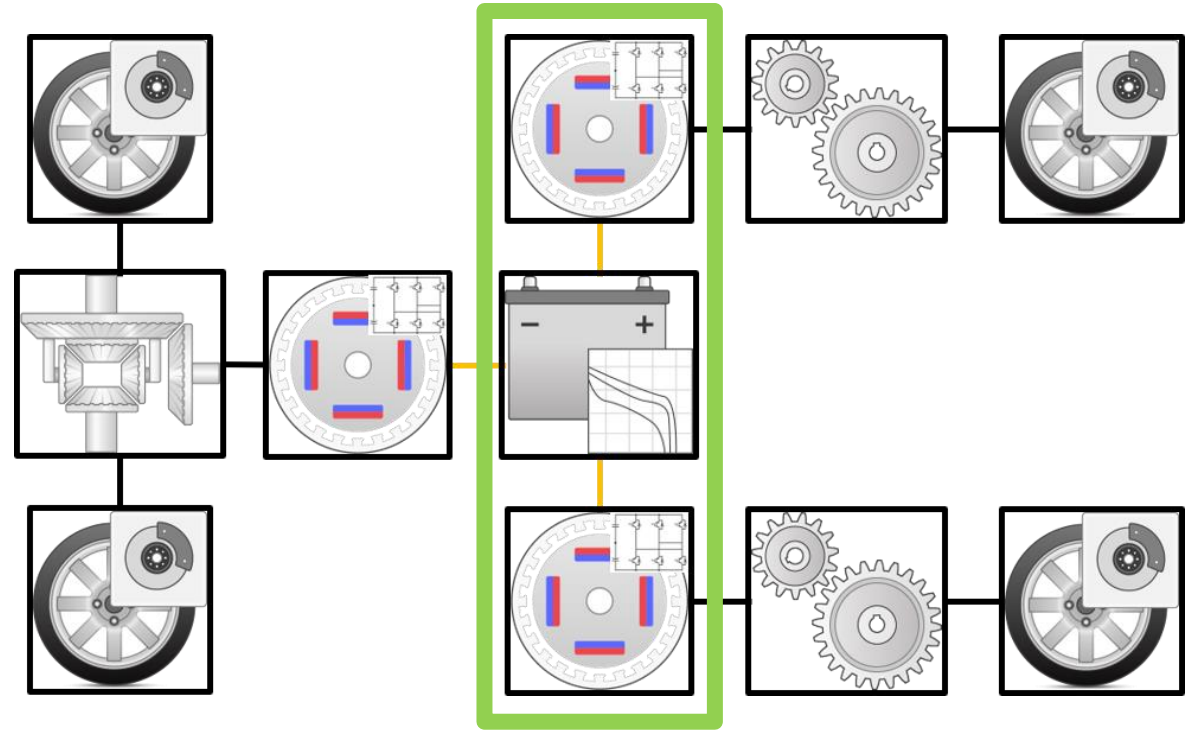

Powertrain System Model

- Mapped Motor
- 14 DOF Body + Wheels

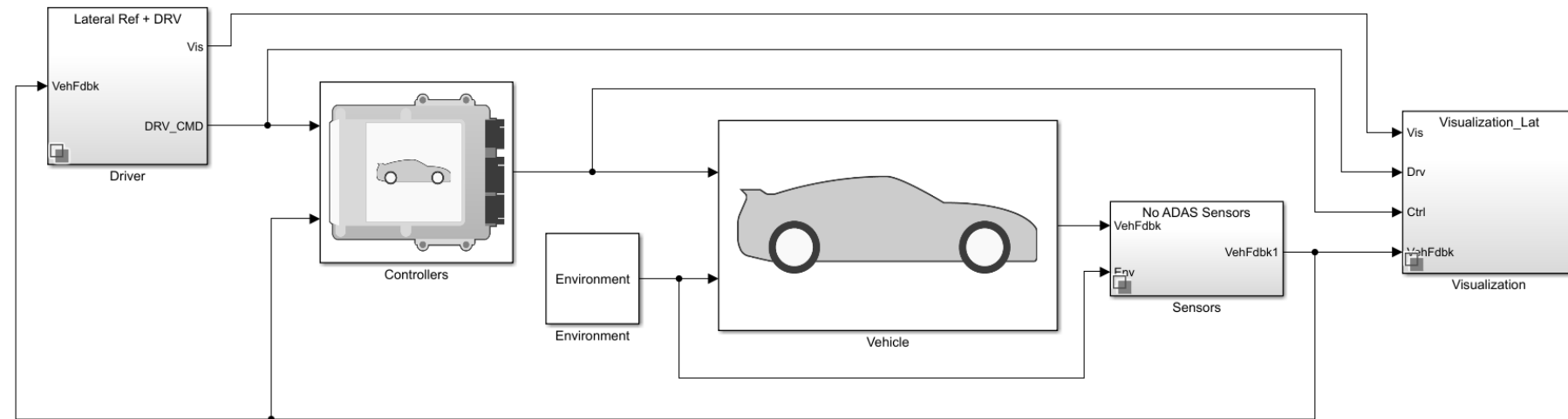
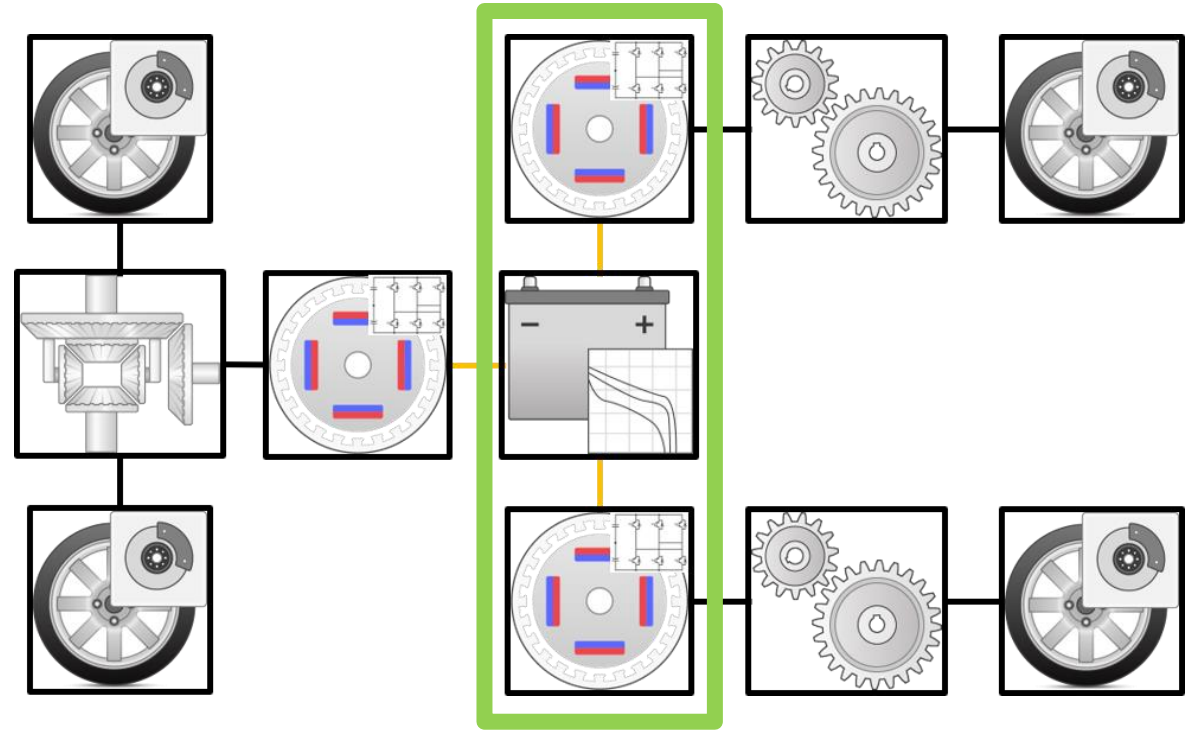

Powertrain System Model

- Mapped Motor
- 14 DOF Body + Wheels
- EV Control Module

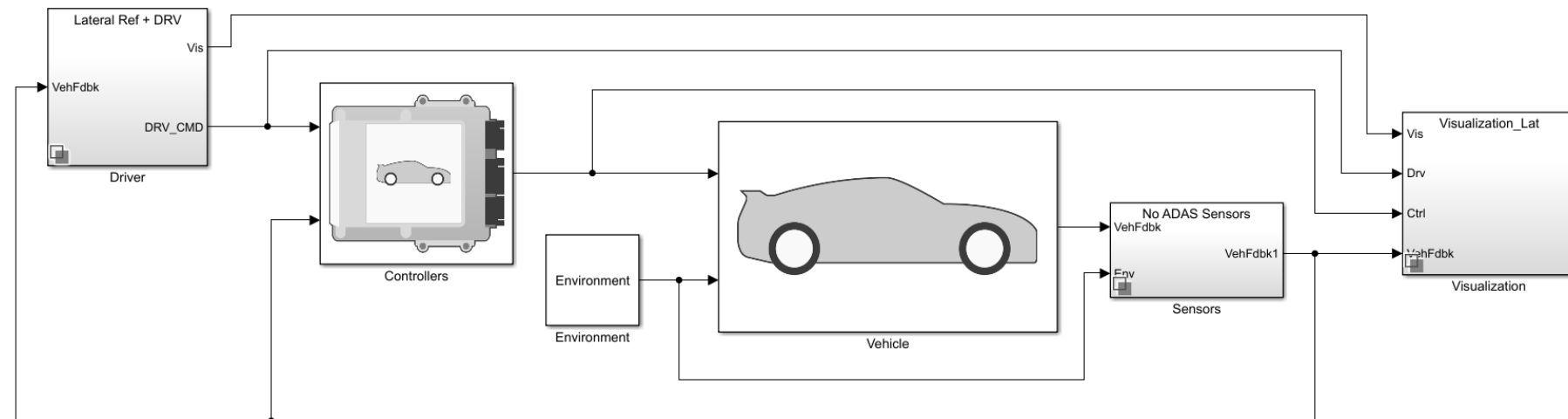
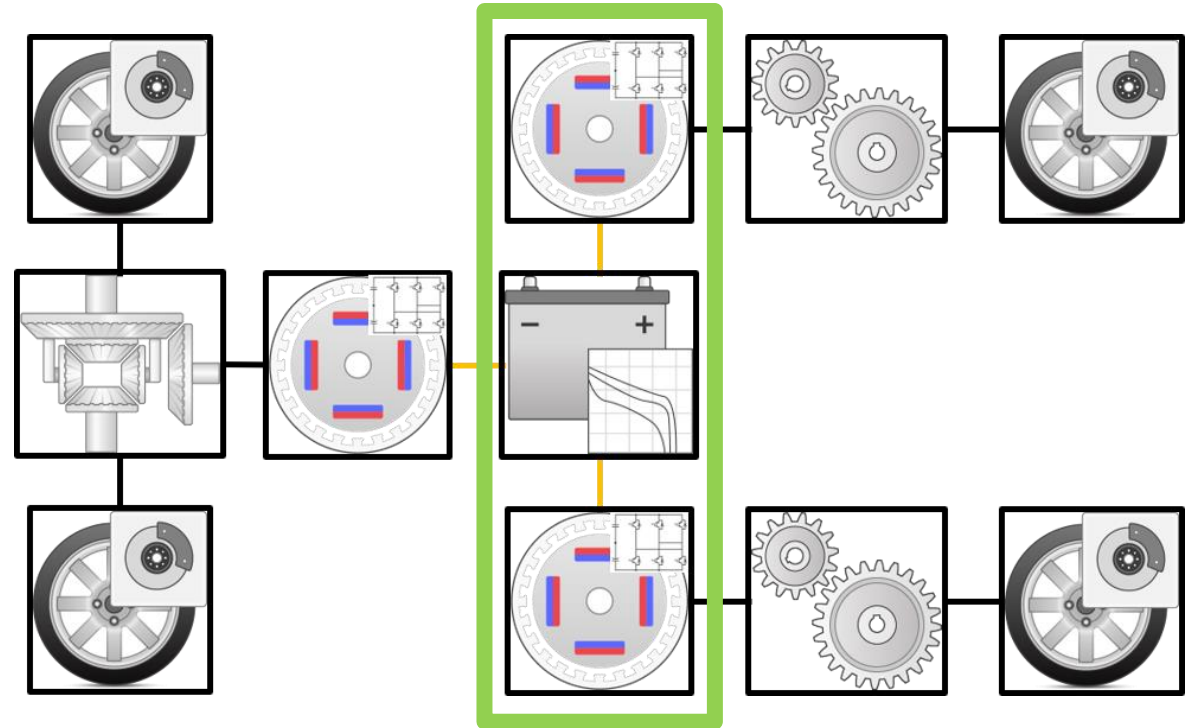

Powertrain System Model

- Mapped Motor
- 14 DOF Body + Wheels
- EV Control Module
- Increasing Steer Maneuver

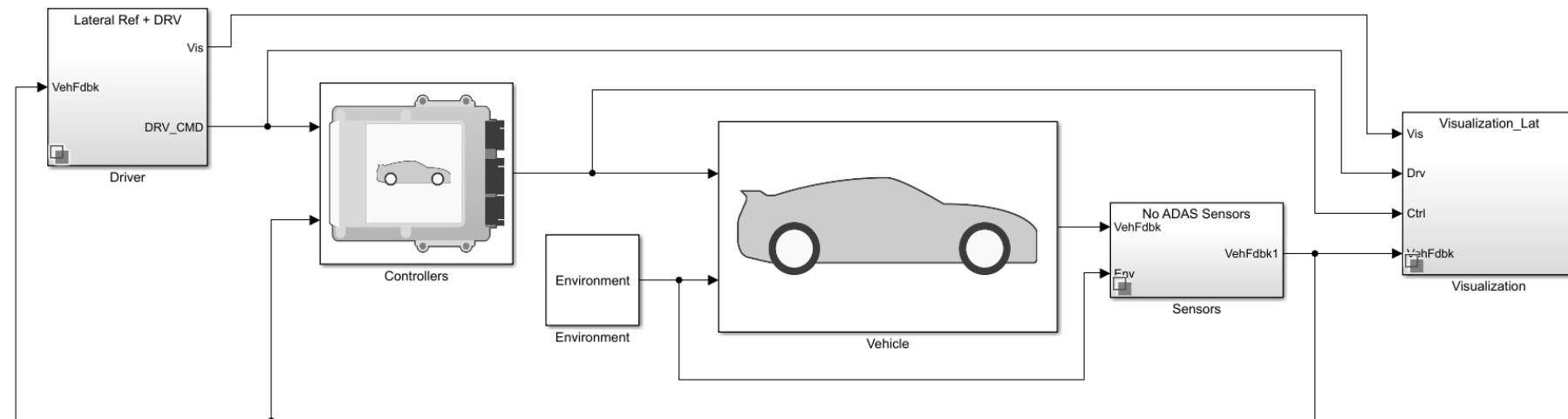
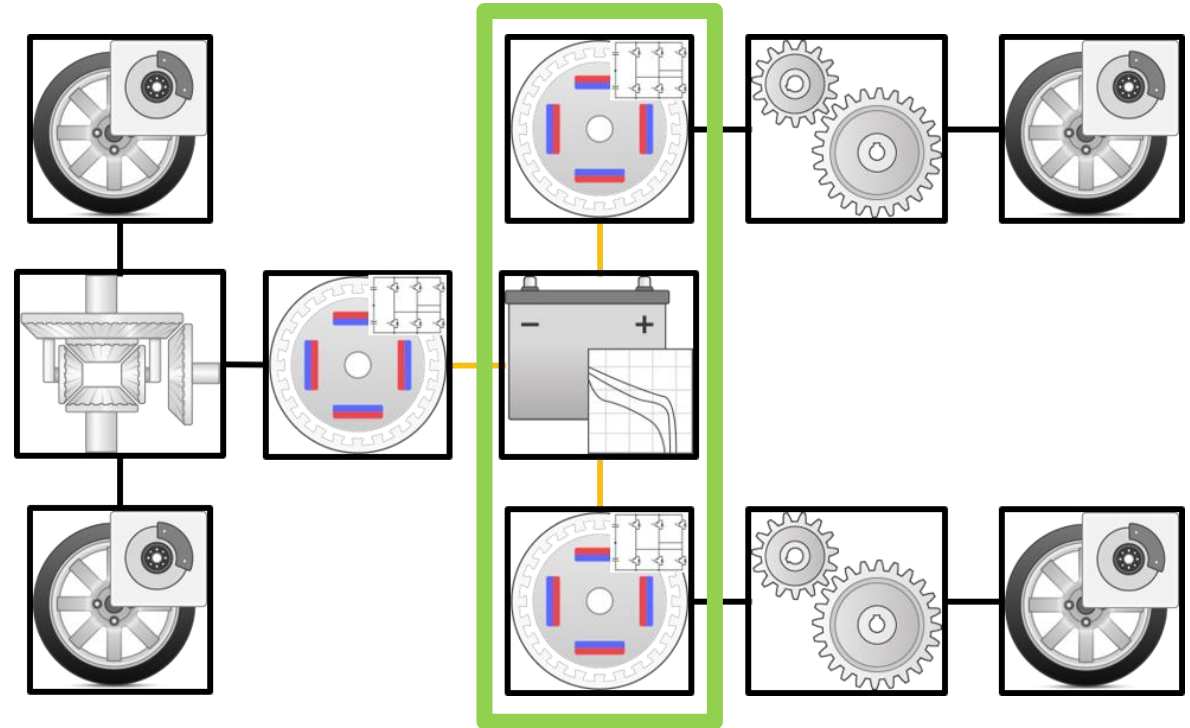

Torque Vectoring Control Deployment

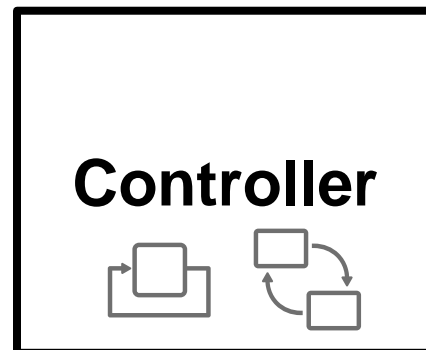
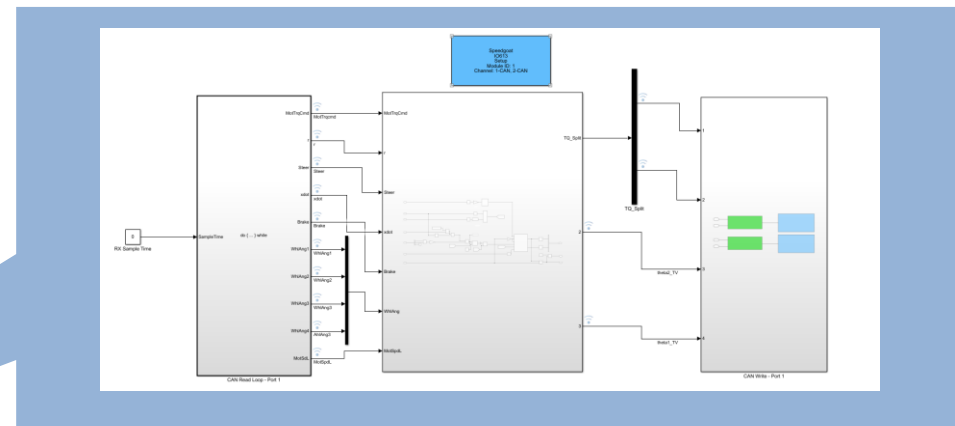

SIMULATION DEBUG MODELING FORMAT REAL-TIME APPS

Project New Open Save Print Library Browser

Model Settings Log Signals Add Viewer

Stop Time: inf Normal Step Back Run Step Forward Stop

Data Inspector Logic Analyzer Bird's-Eye Scope

PREPARE SIMULATE REVIEW RESULTS

Torque_Vectoring_SG

Torque_Vectoring_SG

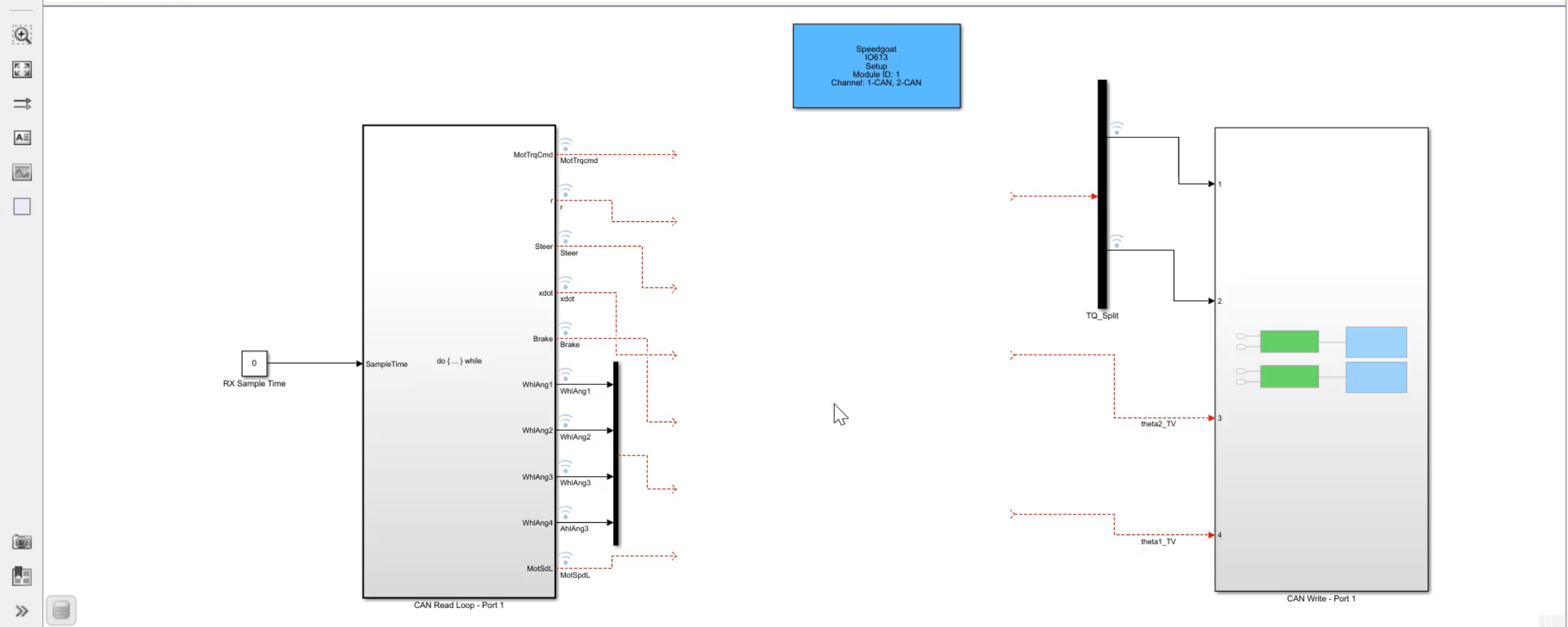

Hardware-in-the-Loop Testing

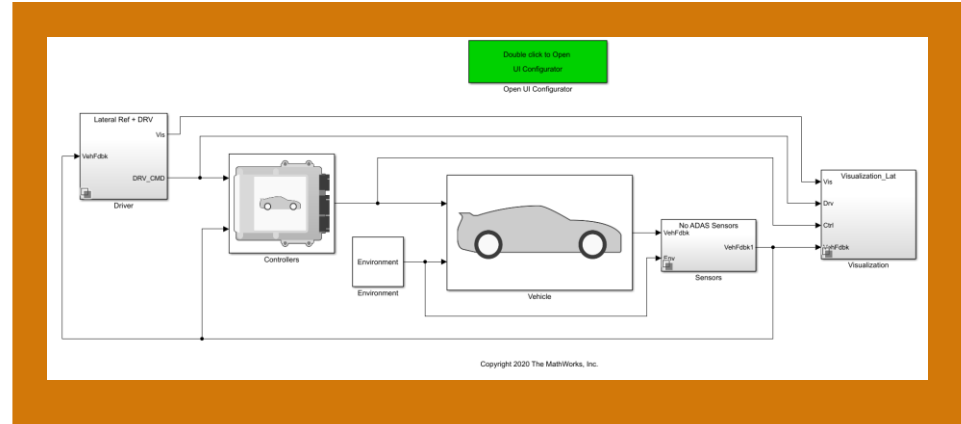

Powertrain & Vehicle Dynamics Model



SIMULATION DEBUG MODELING FORMAT REAL-TIME APPS

slrtEkTg

Connected

Batch Mode Hardware Settings Log Signals

Run on Target

TET Monitor Data Inspector Logic Analyzer

CONNECT TO TARGET COMPUTER PREPARE RUN ON TARGET REVIEW RESULTS

Virtual_Veh_Sim_HIL Visualization_Lat

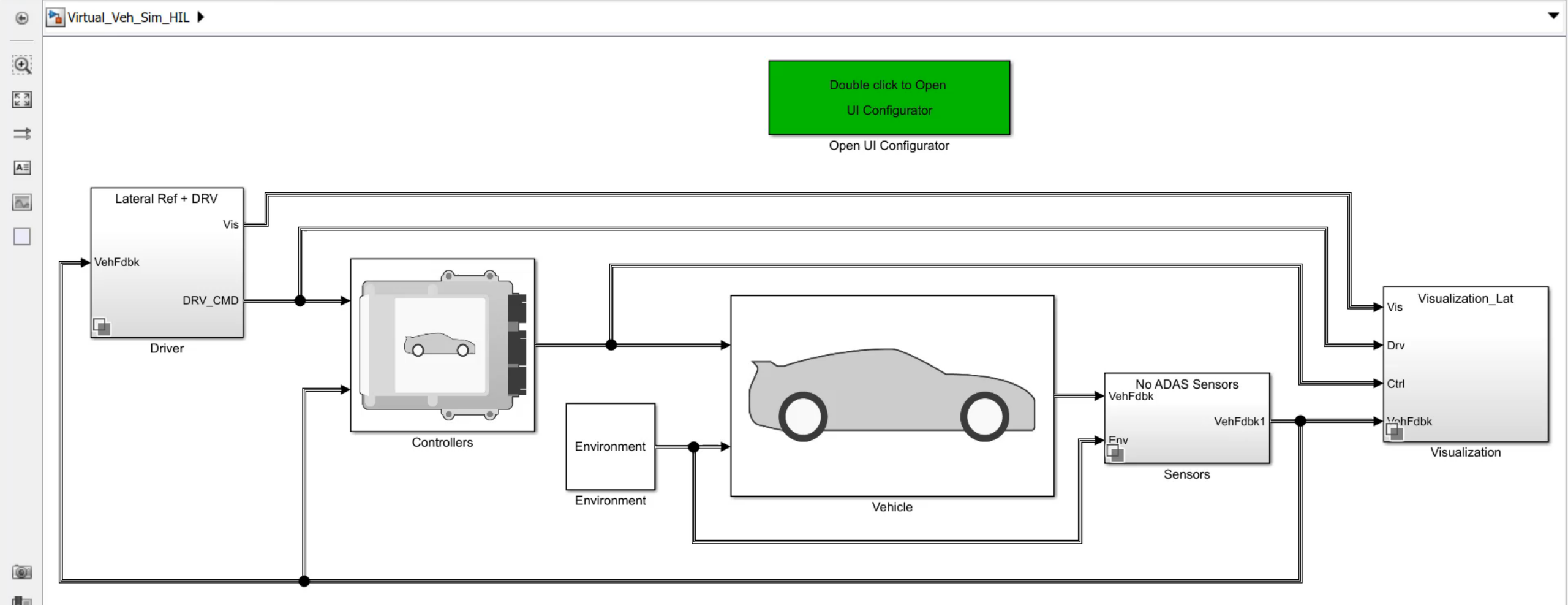

Torque Vectoring Detailed Motor

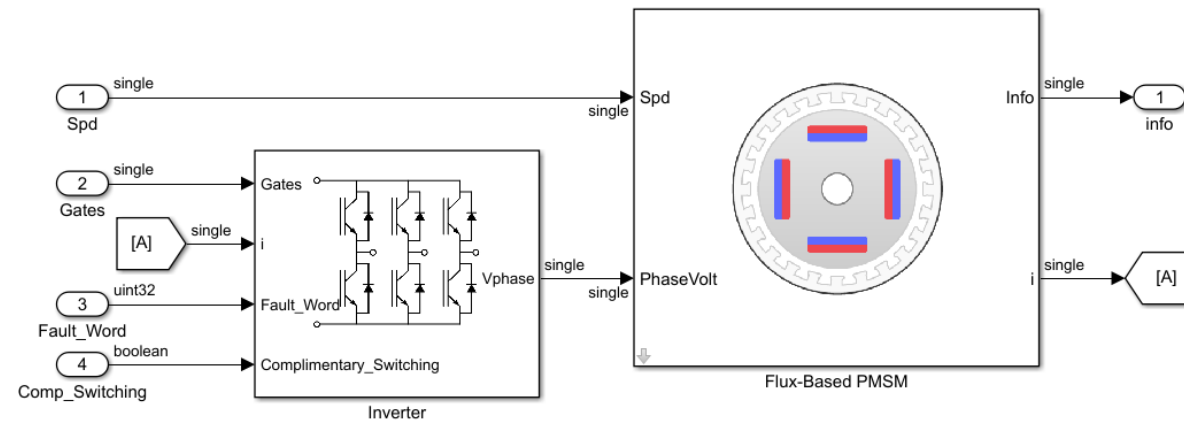
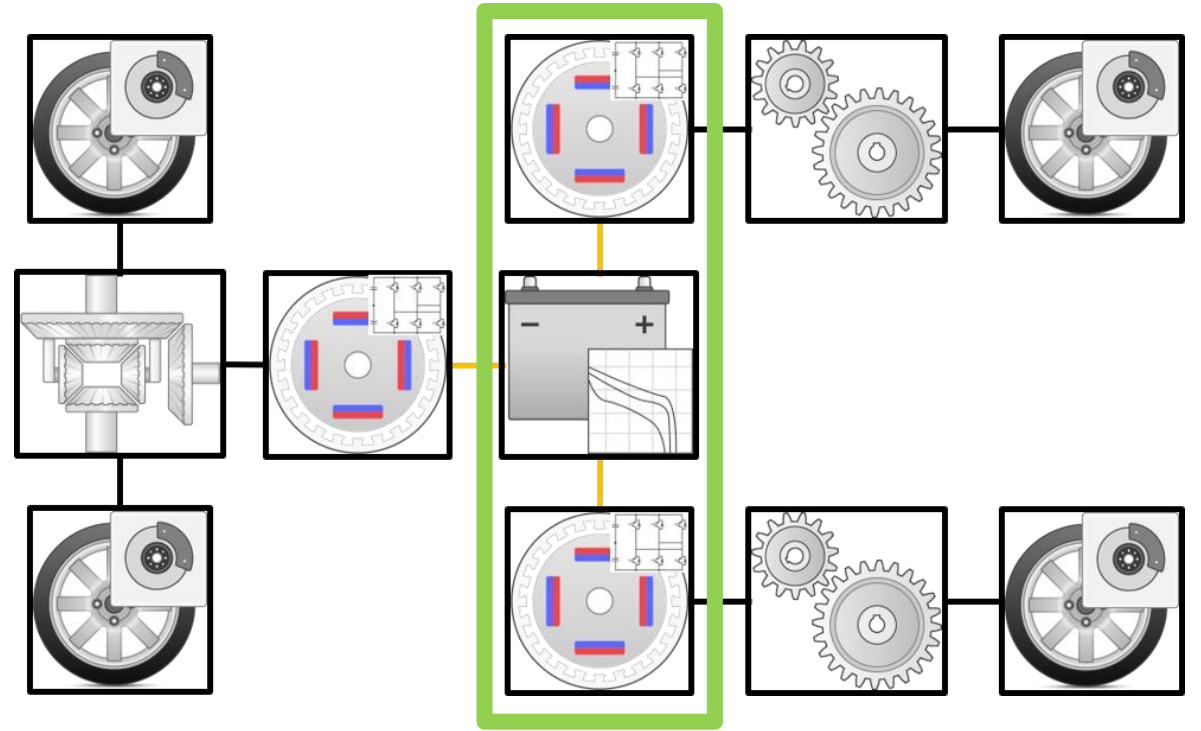
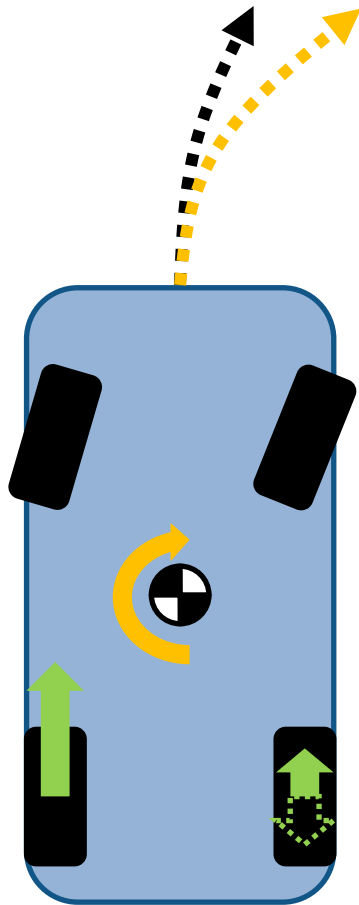

Torque Vectoring Detailed Motor

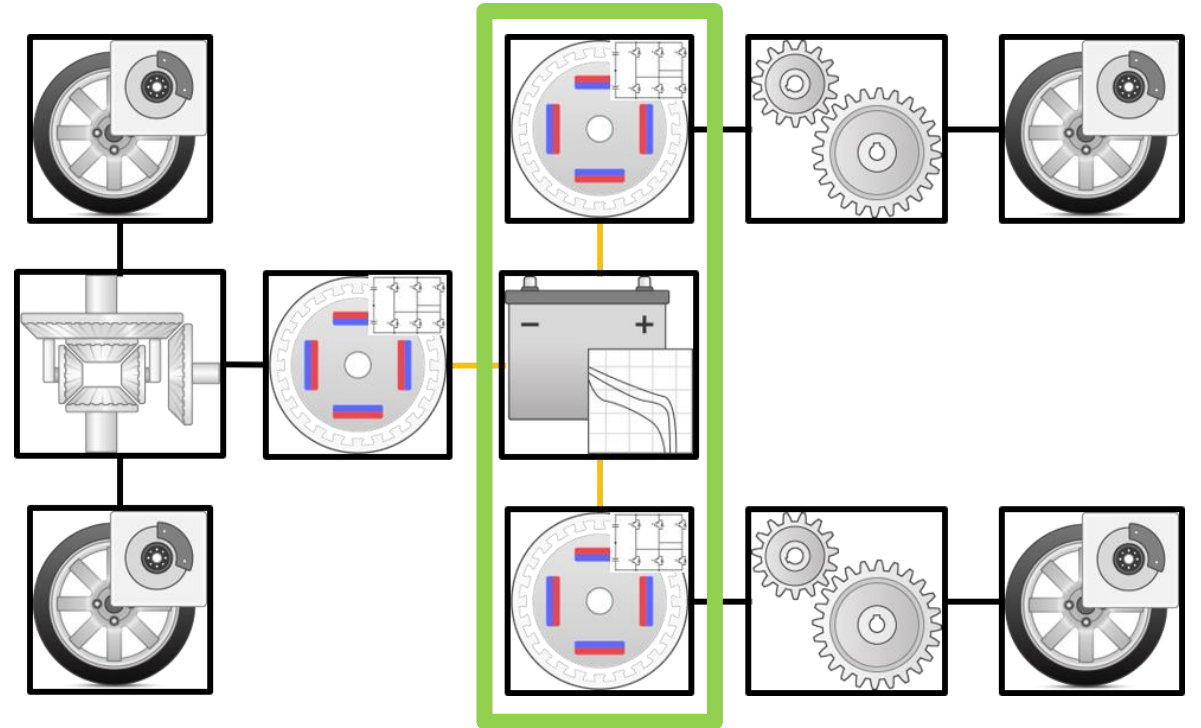
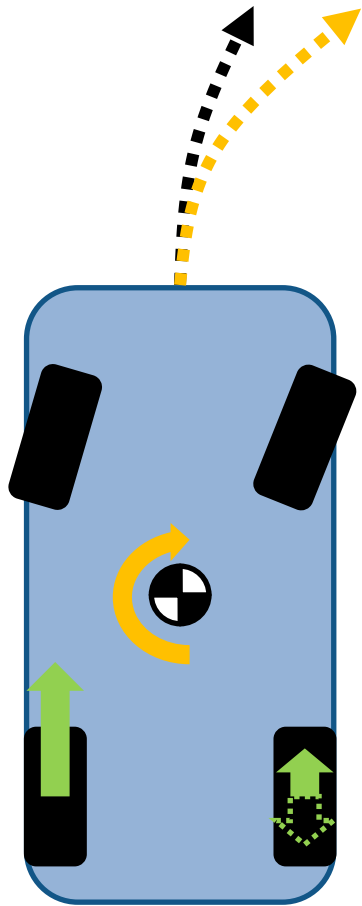

Torque Vectoring Detailed Motor

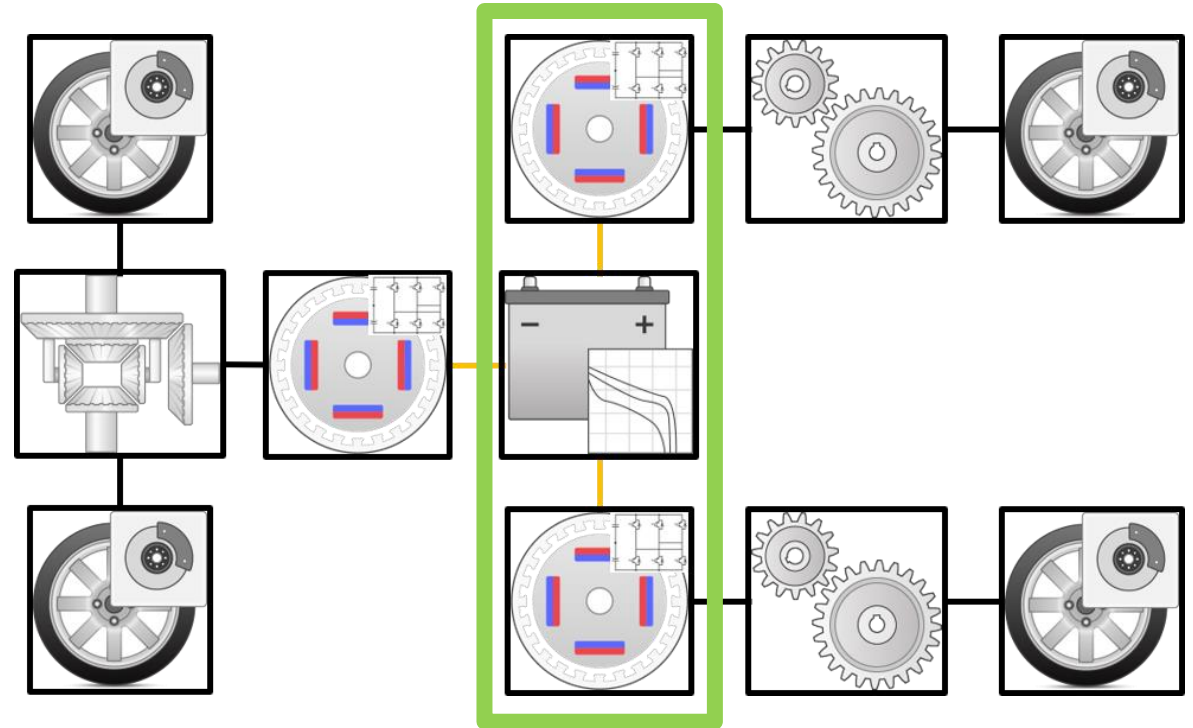
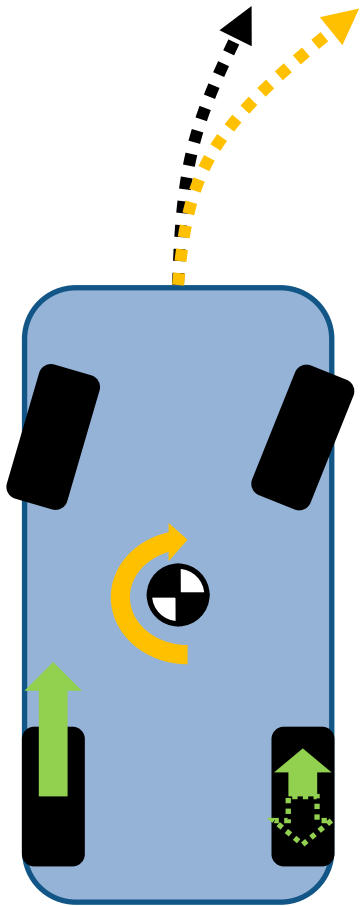

- Motor Control
 - Different levels of fidelity
- Torque vectoring
 - Vehicle Dynamics and Motor Fidelity
 - ECU Testing with Interfaces

Learn More

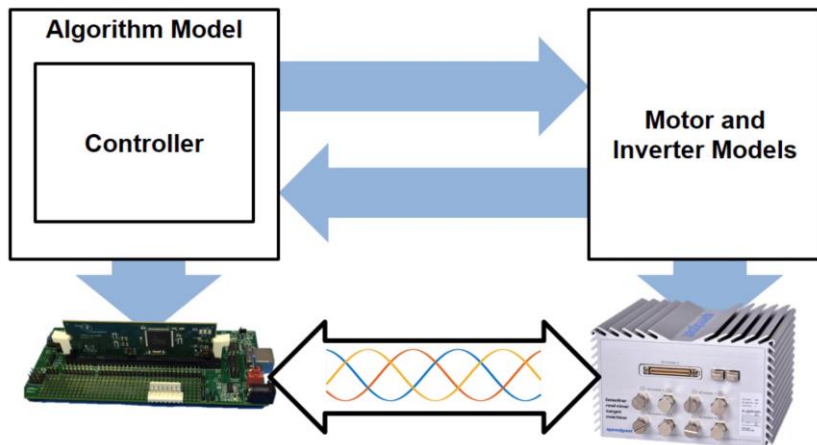

[Accurate Simulation of EV/HEV Power Electronics Switching Events for HiL Testing](#)

[Average HiL Testing of an Electric Motor Controller](#)

- Powertrain Blockset™*
- HDL Coder™*
- Simscape Electrical™*
- Simulink Real-Time™*

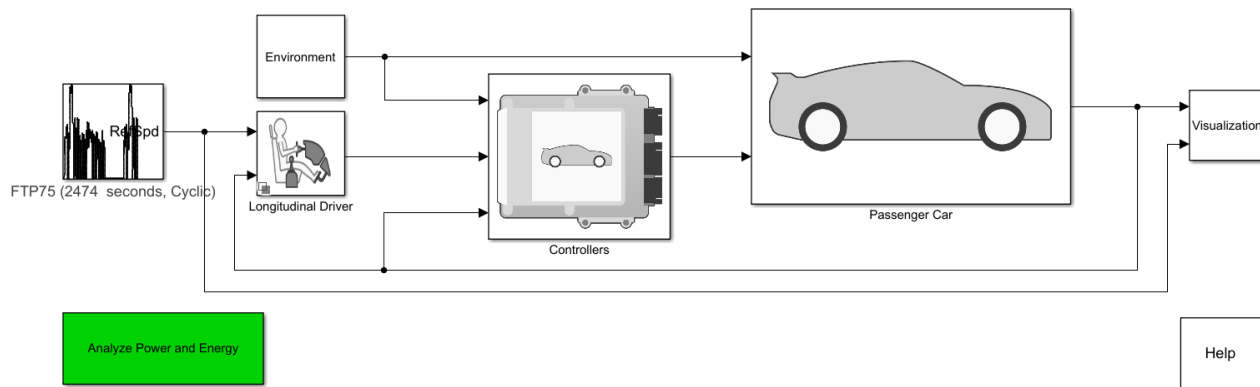

[Full Vehicle Simulation for Electrified Powertrain Selection](#)

- Powertrain Blockset™*
- Vehicle Dynamics Blockset™*

MATLAB EXPO 2021

Thank you

